

LONDON HIGH 680 P 4

ID 203443

Technisches Datenblatt
Technical data sheet



Spezifikationen *Specifications*

ID <i>ID</i>	203443	Material <i>Material</i>	Aluminium	Innendurchmesser <i>Inner diameter</i>	655 mm
Matchcode <i>Matchcode</i>	LondonHigh680P4	Außendurchmesser <i>Outer diameter</i>	680 mm	Durchmesser Rollenaufnahme <i>Diameter of roller holder</i>	11x22 mm
Bezeichnung 1 <i>Designation 1</i>	London High 680 P 4	Höhe <i>Height</i>	315 mm	Hals <i>Neck</i>	22 mm
Artikelgruppe <i>Article group</i>	London High 4	Anzahl Füße <i>Number of feet</i>	4	Oberfläche <i>Surface</i>	Poliert
Basismengeneinheit <i>Base quantityunit</i>	Stk	BIFMA <i>BIFMA</i>	1	Rollenaufnahme <i>Roller holder</i>	11 mm
Gewicht <i>Weight</i>	1.886 kg	Farbe <i>Colour</i>	poliert	Konus <i>Cone</i>	50 mm

LONDON HIGH 680 P 4

ID 203443

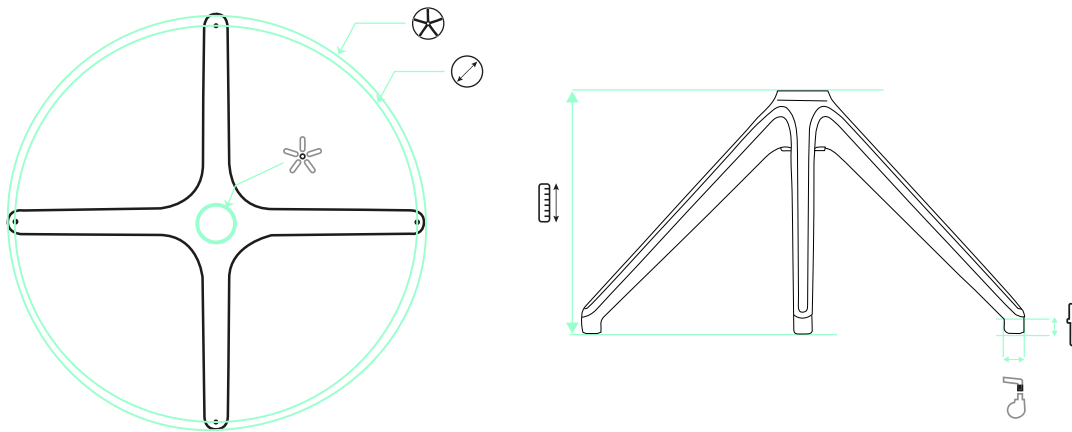

680 mm



655 mm



11x22 mm



22 mm



315 mm



50 mm

EMPFEHLUNGEN RECOMMENDATIONS



SKD 148 C X



SKD 148 S X



155 50 30 3 P U T



166 60 30 3 PU