

# BERLIN 520 P

ID 204015

Technisches Datenblatt  
Technical data sheet



## Spezifikationen Specifications

ID ID	<b>204015</b>	Gewicht Weight	<b>1.3 kg</b>	Innendurchmesser Inner diameter	<b>492 mm</b>
Matchcode Matchcode	<b>Berlin520P</b>	Material Material	<b>Aluminium</b>	Durchmesser Rollenaufnahme Diameter of roller holder	<b>11x22 mm</b>
Bezeichnung 1 Designation 1	<b>Berlin 520 P</b>	Außendurchmesser Outer diameter	<b>520 mm</b>	Hals Neck	<b>28 mm</b>
Artikelgruppe Article group	<b>Berlin 5</b>	Höhe Height	<b>50 mm</b>	Oberfläche Surface	<b>Poliert</b>
Basismengeneinheit Base quantityunit	<b>Stk</b>	Anzahl Füße Number of feet	<b>5</b>	Rollenaufnahme Roller holder	<b>11.2 mm</b>
Menge Karton Quantity carton	<b>6</b>	BIFMA BIFMA	<b>1</b>	Konus Cone	<b>50 mm</b>
Menge Palette Quantity pallet	<b>120</b>	Farbe Colour	<b>poliert</b>		

# BERLIN 520 P

ID 204015

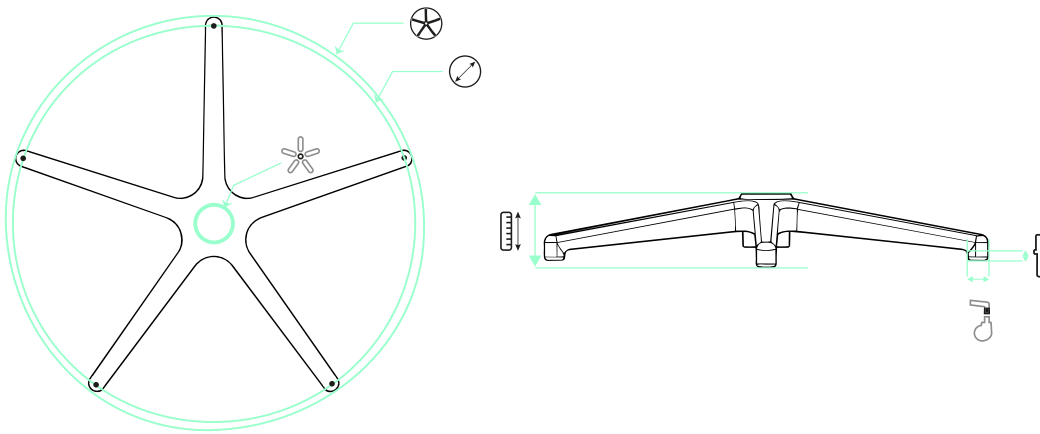

520 mm



492 mm

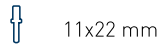

11x22 mm



28 mm



50 mm



50 mm

## EMPFEHLUNGEN RECOMMENDATIONS



S 235 290 132 K 70 C X



S 235 290 132 K 70 S X



155 H28 65 30 3 PU



166 60 30 3 PU