

FLAKE 688 KU

ID 204960

Technisches Datenblatt
Technical data sheet



Spezifikationen Specifications

ID <i>ID</i>	204960	Gewicht <i>Weight</i>	1.649 kg	Innendurchmesser <i>Inner diameter</i>	662 mm
Matchcode <i>Matchcode</i>	Flake688KU	Material <i>Material</i>	Kunststoff	Durchmesser Rollenaufnahme <i>Diameter of roller holder</i>	11x22 mm
Bezeichnung 1 <i>Designation 1</i>	Flake 688 KU	Außendurchmesser <i>Outer diameter</i>	690 mm	Hals <i>Neck</i>	28 mm
Artikelgruppe <i>Article group</i>	Flake KU	Höhe <i>Height</i>	108 mm	Oberfläche <i>Surface</i>	Feinstruktur
Basismengeneinheit <i>Base quantityunit</i>	Stk	Anzahl Füße <i>Number of feet</i>	5	Rollenaufnahme <i>Roller holder</i>	11 mm
Menge Karton <i>Quantity carton</i>	5	BIFMA <i>BIFMA</i>	1	Konus <i>Cone</i>	50 mm
Menge Palette <i>Quantity pallet</i>	100	Farbe <i>Colour</i>	schwarz		

FLAKE 688 KU

ID 204960

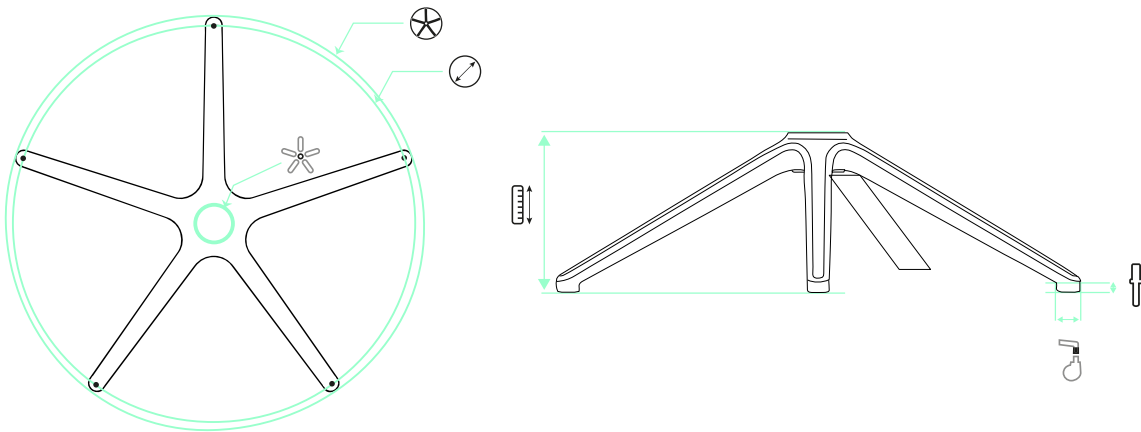

690 mm



662 mm



11x22 mm



28 mm



108 mm



50 mm

EMPFEHLUNGEN RECOMMENDATIONS



S 235 290 132 K 70 C X



S 235 290 132 K 70 S X



155 H28 65 30 3 PU



166 60 30 3 PU