

STELLAR 690 MIDDLE 5 P

ID 205884

Technisches Datenblatt
Technical data sheet



Spezifikationen Specifications

ID <i>ID</i>	205884	Gewicht <i>Weight</i>	3.11 kg	Innendurchmesser <i>Inner diameter</i>	668 mm
Matchcode <i>Matchcode</i>	STELLAR690Middle5P	Material <i>Material</i>	Aluminium	Durchmesser Rollenaufnahme <i>Diameter of roller holder</i>	11x22 mm
Bezeichnung 1 <i>Designation 1</i>	STELLAR 690 Middle 5 P	Außendurchmesser <i>Outer diameter</i>	690 mm	Hals <i>Neck</i>	22 mm
Artikelgruppe <i>Article group</i>	Stellar Middle 5	Höhe <i>Height</i>	194 mm	Oberfläche <i>Surface</i>	Poliert
Basismengeneinheit <i>Base quantityunit</i>	Stk	Anzahl Füße <i>Number of feet</i>	5	Rollenaufnahme <i>Roller holder</i>	11 mm
Menge Karton <i>Quantity carton</i>	4	BIFMA <i>BIFMA</i>	1	Konus <i>Cone</i>	50 mm
Menge Palette <i>Quantity pallet</i>	64	Farbe <i>Colour</i>	poliert		

STELLAR 690 MIDDLE 5 P

ID 205884

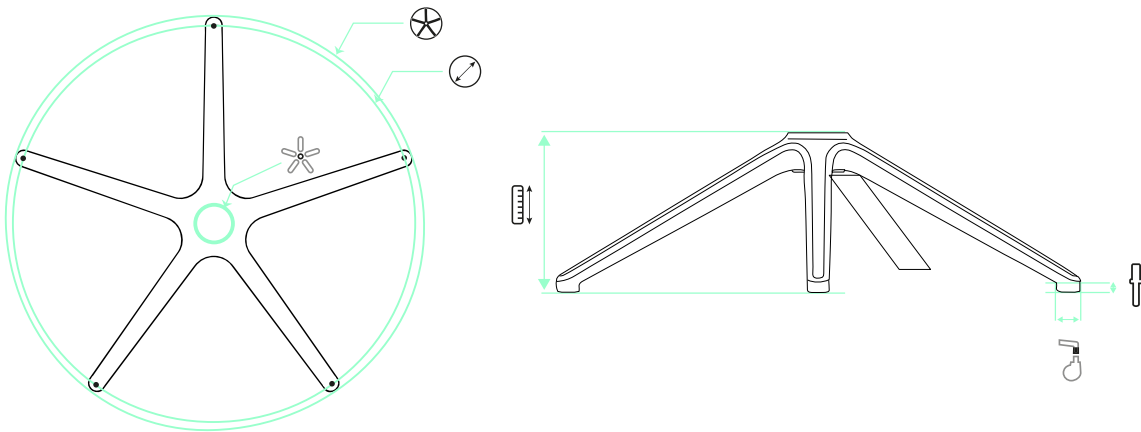

690 mm



668 mm



11x22 mm



22 mm



194 mm



50 mm

EMPFEHLUNGEN RECOMMENDATIONS



S 235 290 132 K 70 C X



S 235 290 132 K 70 S X



155 H16 50 30 3 P U



166 60 30 3 PU



Tendo P