

STELLAR 690 HIGH 4 S

ID 205936

Technisches Datenblatt
Technical data sheet





Spezifikationen Specifications

ID ID	205936	Material Material	Aluminium	Innendurchmesser Inner diameter	668 mm
Matchcode Matchcode	STELLAR690High4S	Außendurchmesser Outer diameter	690 mm	Durchmesser Rollenaufnahme Diameter of roller holder	11x22 mm
Bezeichnung 1 Designation 1	STELLAR 690 High 4 S	Höhe Height	320 mm	Hals Neck	22 mm
Artikelgruppe Article group	Stellar High	Anzahl Füße Number of feet	4	Oberfläche Surface	Gepulvert
Basismengeneinheit Base quantityunit	Stk	BIFMA BIFMA	1	Rollenaufnahme Roller holder	11 mm
Gewicht Weight	1.3 kg	Farbe Colour	schwarz	Konus Cone	50 mm

STELLAR 690 HIGH 4 S

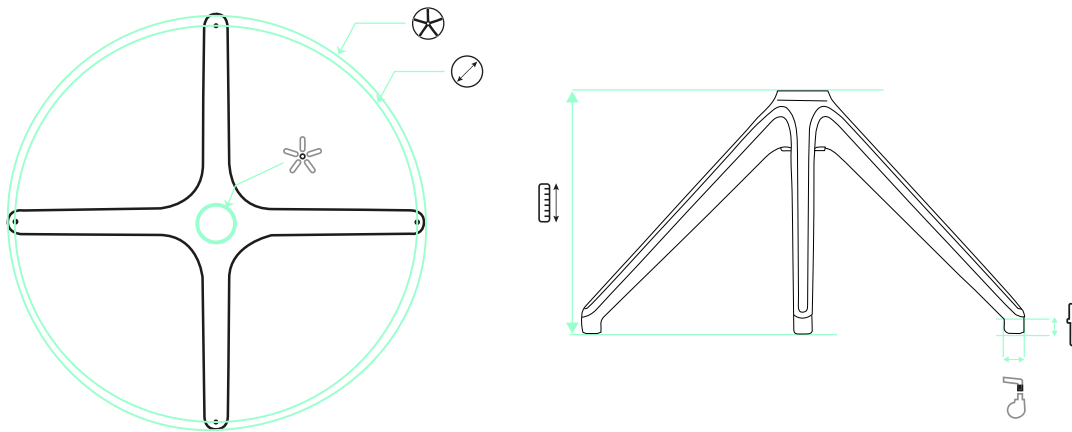
ID 205936



 690 mm

 668 mm

 11x22 mm

 22 mm

 320 mm

 50 mm

EMPFEHLUNGEN RECOMMENDATIONS



SKD 148 C X



SKD 148 S X



155 H16 50 30 3 P U



166 60 30 3 PU



Tendo P