

AF 270 P

ID 200946

Technisches Datenblatt
Technical data sheet



Spezifikationen *Specifications*

ID <i>ID</i>	200946	Gewicht <i>Weight</i>	1.8 kg	Innendurchmesser <i>Inner diameter</i>	632 mm
Matchcode <i>Matchcode</i>	AF270P	Material <i>Material</i>	Aluminium	Durchmesser Rollenaufnahme <i>Diameter of roller holder</i>	11x22 mm
Bezeichnung 1 <i>Designation 1</i>	AF 270 P	Außendurchmesser <i>Outer diameter</i>	662 mm	Hals <i>Neck</i>	30 mm
Artikelgruppe <i>Article group</i>	AF270	Höhe <i>Height</i>	60 mm	Oberfläche <i>Surface</i>	Poliert
Basismengeneinheit <i>Base quantityunit</i>	Stk	Anzahl Füße <i>Number of feet</i>	5	Rollenaufnahme <i>Roller holder</i>	11 mm
Menge Karton <i>Quantity carton</i>	6	BIFMA <i>BIFMA</i>	1	Konus <i>Cone</i>	50 mm
Menge Palette <i>Quantity pallet</i>	120	Farbe <i>Colour</i>	poliert		

AF 270 P

ID 200946

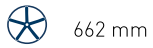
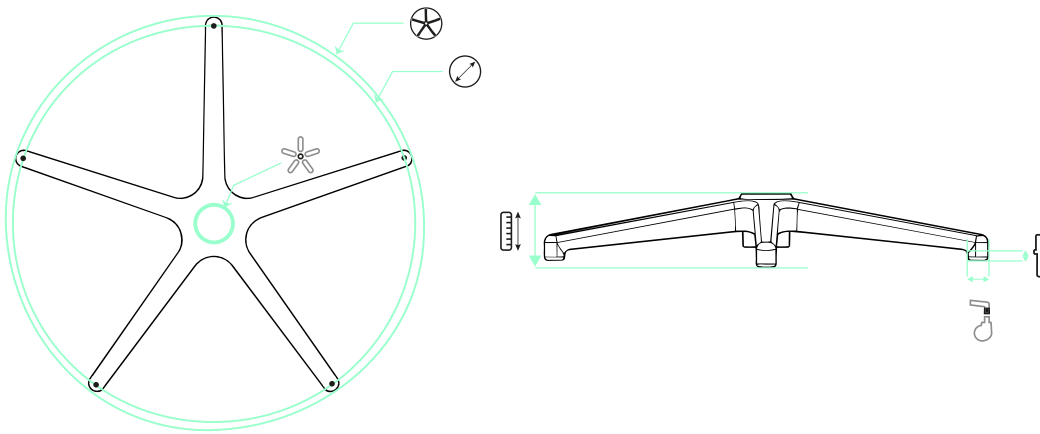

662 mm



632 mm



11x22 mm



30 mm



60 mm



50 mm

EMPFEHLUNGEN RECOMMENDATIONS



S 235 290 132 K 70 C X



S 235 290 132 K 70 S X



155 H28 65 30 3 PU



166 60 30 3 PU