

S 465 526 250 K 50 S X

ID 201576

Technisches Datenblatt
Technical data sheet



Spezifikationen Specifications

ID ID	201576	Farbe Colour	schwarz	Gesamthöhe Höchste Total height Highest p	776 mm	Drehbar Rotatable	1
Matchcode Matchcode	S465526250K50SX	Gesamthöhe niedrigs Total height lowest p	526 mm	Standrohrlänge Standpipe length	465 mm		
Bezeichnung 1 Designation 1	S 465 526 250 K 50	Hub Stroke	250 mm	Standrohrdurchmess Standpipe diameter	50 mm		
Artikelgruppe Article group	Standard Line Schw	Gewichtsgrenze Weight limit	140 kg	Aufbauhöhe ab Fuß M Build-up height from	476 mm		
Basismengeneinheit Base quantityunit	Stk	Klasse Class	4	Aufbauhöhe ab Fuß M Installation height fro	726 mm		
Menge Karton Quantity carton	10	Durchmesser Gaseinl Diameter gas unit	28 mm	Material	Stahlblech		
Menge Palette Quantity pallet	420	Konuslänge Gaseinhe Cone length gas unit	33 mm	Druck Pressure	320 N		
Gewicht Weight	2.165 kg	Konuslänge Cone length	50 mm	Höhenverstellbar Heightadjustable	1		

S 465 526 250 K 50 S X

ID 201576

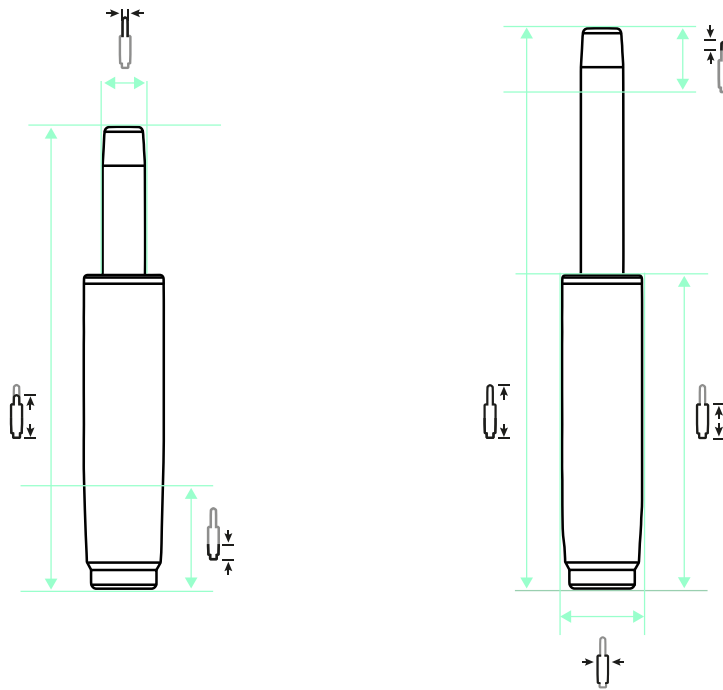

250 mm |
 776 mm |
 526 mm |
 465 mm |
 50 mm |
 33 mm |
 50 mm |
 28 mm |
 320 N

ZUBEHÖR ACCESSORIES



AD 38 / 50



AD 40 / 50



ÜS-Rohr 183



ÜS-Rohr 244



ÜS-Rohr 298

EMPFEHLUNGEN RECOMMENDATIONS



STELLAR 690 Middle 5 P



STELLAR 690 Middle 5 S



North 1 Alu-Mechanik P



Threesixty