

S 305 373 192 K 70 S X 200 N

ID 202989

Technisches Datenblatt
Technical data sheet



Spezifikationen Specifications

ID ID	202989	Farbe Colour	schwarz	Gesamthöhe Höchste Total height Highest p	565 mm	Drehbar Rotatable	1
Matchcode Matchcode	S305373192K70SX2	Gesamthöhe niedrigs Total height lowest po	373 mm	Standrohrlänge Standpipe length	305 mm		
Bezeichnung 1 Designation 1	S 305 373 192 K 70	Hub Stroke	192 mm	Standrohrdurchmess Standpipe diameter	50 mm		
Artikelgruppe Article group	Standard Line Schw	Gewichtsgrenze Weight limit	140 kg	Aufbauhöhe ab Fuß M Build-up height from	303 mm		
Basismengeneinheit Base quantityunit	Stk	Klasse Class	4	Aufbauhöhe ab Fuß M Installation height fro	495 mm		
Menge Karton Quantity carton	10	Durchmesser Gaseinl Diameter gas unit	28 mm	Material	Stahlblech		
Menge Palette Quantity pallet	420	Konuslänge Gaseinhe Cone length gas unit	33 mm	Druck Pressure	200 N		
Gewicht Weight	1.517 kg	Konuslänge Cone length	70 mm	Höhenverstellbar Heightadjustable	1		

S 305 373 192 K 70 S X 200 N

ID 202989

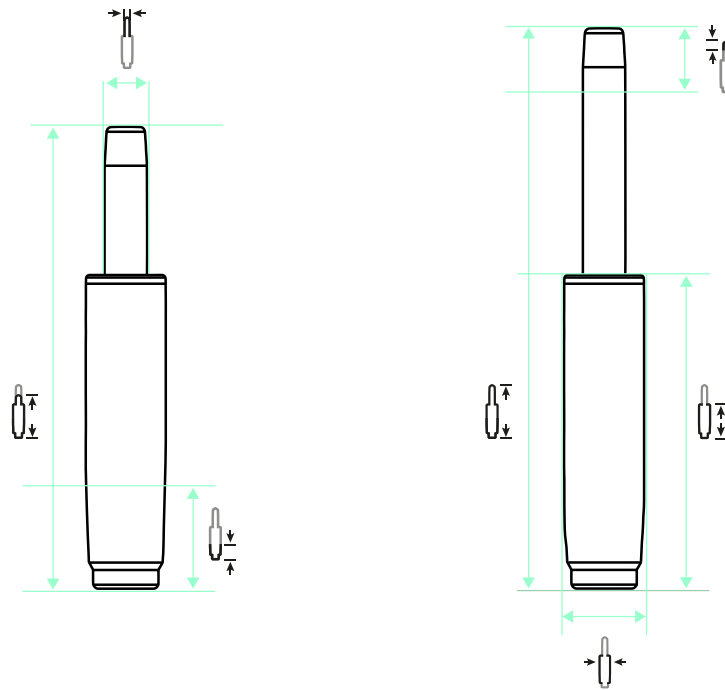

192 mm |
 565 mm |
 373 mm |
 305 mm |
 70 mm |
 33 mm |
 50 mm |
 28 mm |
 200 N

ZUBEHÖR ACCESSORIES



AD 38 / 50



AD 40 / 50



ÜS-Rohr 183



ÜS-Rohr 244



ÜS-Rohr 298

EMPFEHLUNGEN RECOMMENDATIONS



STELLAR 690 Middle 5 P



STELLAR 690 Middle 5 S



North 1 Alu-Mechanik P



Threesixty