

S 375 431 262 K 70 C X ESD

ID 204258

Technisches Datenblatt
Technical data sheet



Spezifikationen Specifications

ID ID	204258	Farbe Colour	chrom	Gesamthöhe Höchste Total height Highest p	693 mm	Drehbar Rotatable	1
Matchcode Matchcode	S375431262K70CXI	Gesamthöhe niedrigs Total height lowest p	431 mm	Standrohrlänge Standpipe length	375 mm		
Bezeichnung 1 Designation 1	S 375 431 262 K 70	Hub Stroke	262 mm	Standrohrdurchmess Standpipe diameter	50 mm		
Artikelgruppe Article group	Standard Line Chro	Gewichtsgrenze Weight limit	140 kg	Aufbauhöhe ab Fuß M Build-up height from	360 mm		
Basismengeneinheit Base quantityunit	Stk	Klasse Class	4	Aufbauhöhe ab Fuß M Installation height fro	620 mm		
Menge Karton Quantity carton	10	Durchmesser Gaseinl Diameter gas unit	28 mm	Material	Stahlblech		
Menge Palette Quantity pallet	420	Konuslänge Gaseinhe Cone length gas unit	33 mm	Druck Pressure	320 N		
Gewicht Weight	1.8 kg	Konuslänge Cone length	70 mm	Höhenverstellbar Heightadjustable	1		

S 375 431 262 K 70 C X ESD

ID 204258

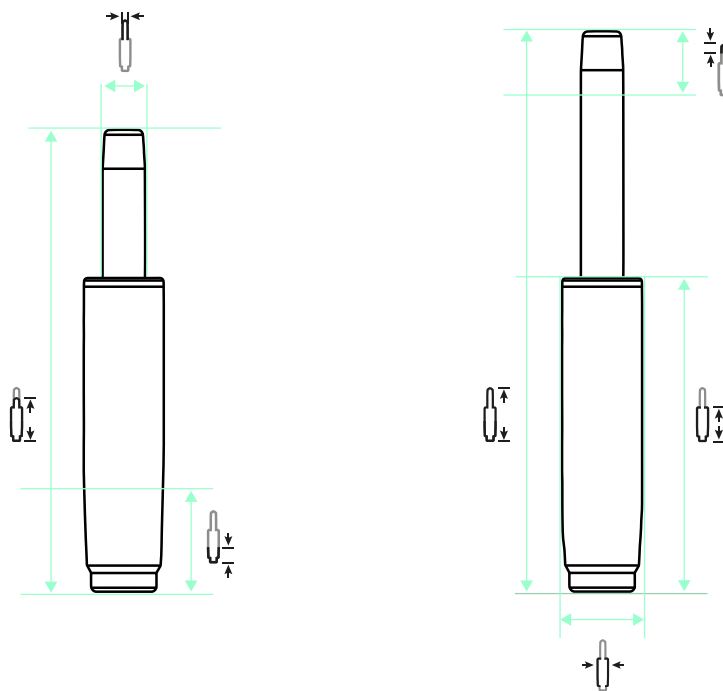

262 mm |
 693 mm |
 431 mm |
 375 mm |
 70 mm |
 33 mm |
 50 mm |
 28 mm |
 320 N

ZUBEHÖR ACCESSORIES



AD 38 / 50



AD 40 / 50



ÜS-Rohr 183



ÜS-Rohr 244



ÜS-Rohr 298

EMPFEHLUNGEN RECOMMENDATIONS



STELLAR 690 Middle 5 P



STELLAR 690 Middle 5 S



North 1 Alu-Mechanik P



Threesixty