

S 256 308 155 K 70 C X ESD

ID 204260

Technisches Datenblatt
Technical data sheet



Spezifikationen Specifications

ID ID	204260	Farbe Colour	chrom	Gesamthöhe Höchste Total height Highest p	465 mm	Drehbar Rotatable	1
Matchcode Matchcode	S256308155K70CX	Gesamthöhe niedrigs Total height lowest p	308 mm	Standrohrlänge Standpipe length	255 mm		
Bezeichnung 1 Designation 1	S 256 308 155 K 70	Hub Stroke	157 mm	Standrohrdurchmess Standpipe diameter	50 mm		
Artikelgruppe Article group	Standard Line Chrom	Gewichtsgrenze Weight limit	140 kg	Aufbauhöhe ab Fuß M Build-up height from	238 mm		
Basismengeneinheit Base quantityunit	Stk	Klasse Class	4	Aufbauhöhe ab Fuß M Installation height fro	393 mm		
Menge Karton Quantity carton	0	Durchmesser Gaseinl Diameter gas unit	28 mm	Material	Stahlblech		
Menge Palette Quantity pallet	0	Konuslänge Gaseinhe Cone length gas unit	33 mm	Druck Pressure	320 N		
Gewicht Weight	1.258 kg	Konuslänge Cone length	70 mm	Höhenverstellbar Heightadjustable	1		

S 256 308 155 K 70 C X ESD

ID 204260

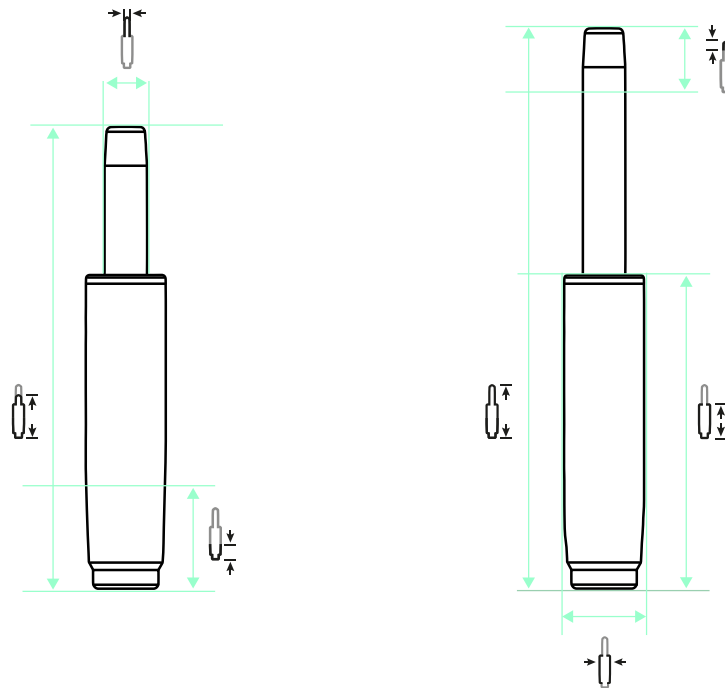

 157 mm |
  465 mm |
  308 mm |
  255 mm |
  70 mm |
  33 mm |
  50 mm |
  28 mm |
  320 N

ZUBEHÖR ACCESSORIES



AD 38 / 50



AD 40 / 50



ÜS-Rohr 183



ÜS-Rohr 244



ÜS-Rohr 298

EMPFEHLUNGEN RECOMMENDATIONS



STELLAR 690 Middle 5 P



STELLAR 690 Middle 5 S



North 1 Alu-Mechanik P



Threesixty