

S 256 308 157 K 70 S X 200 N

ID 205302

Technisches Datenblatt
Technical data sheet



Spezifikationen Specifications

ID ID	205302	Farbe Colour	schwarz	Gesamthöhe Höchste Total height Highest p	465 mm	Drehbar Rotatable	1
Matchcode Matchcode	S256308157K70SX2	Gesamthöhe niedrigs Total height lowest p	308 mm	Standrohrlänge Standpipe length	255 mm		
Bezeichnung 1 Designation 1	S 256 308 157 K 70	Hub Stroke	157 mm	Standrohrdurchmess Standpipe diameter	50 mm		
Artikelgruppe Article group	Standard Line Schw	Gewichtsgrenze Weight limit	140 kg	Aufbauhöhe ab Fuß M Build-up height from	238 mm		
Basismengeneinheit Base quantityunit	Stk	Klasse Class	4	Aufbauhöhe ab Fuß M Installation height fro	395 mm		
Menge Karton Quantity carton	20	Durchmesser Gaseinl Diameter gas unit	28 mm	Material	Stahlblech		
Menge Palette Quantity pallet	600	Konuslänge Gaseinhe Cone length gas unit	33 mm	Druck Pressure	200 N		
Gewicht Weight	1.258 kg	Konuslänge Cone length	70 mm	Höhenverstellbar Heightadjustable	1		

S 256 308 157 K 70 S X 200 N

ID 205302

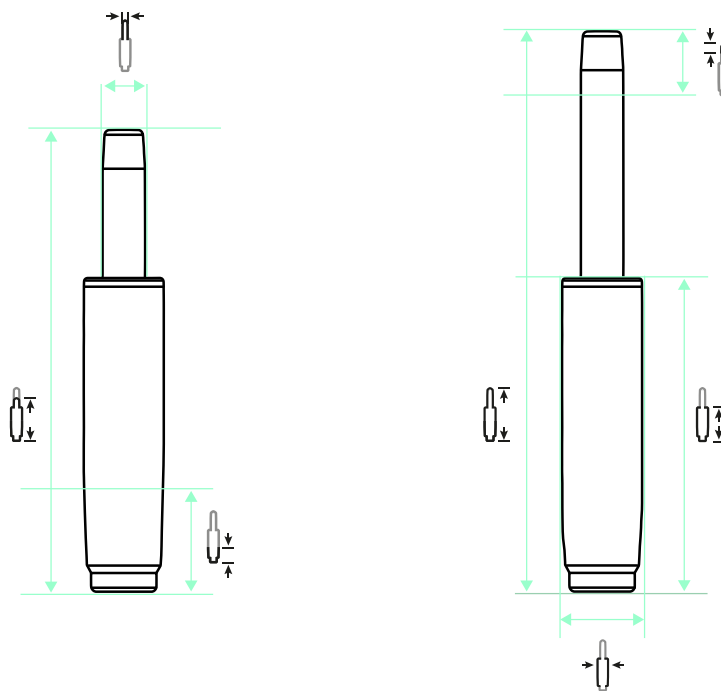

157 mm |
 465 mm |
 308 mm |
 25 mm |
 70 mm |
 33 mm |
 50 mm |
 28 mm |
 200 N

ZUBEHÖR ACCESSORIES



AD 38 / 50



AD 40 / 50



ÜS-Rohr 183



ÜS-Rohr 244



ÜS-Rohr 298

EMPFEHLUNGEN RECOMMENDATIONS



STELLAR 690 Middle 5 P



STELLAR 690 Middle 5 S



North 1 Alu-Mechanik P



Threesixty