

S 215 257 122 K 98 C X ESD

ID 205673

Technisches Datenblatt
Technical data sheet



Spezifikationen Specifications

ID ID	205673	Farbe Colour	chrom	Gesamthöhe Höchste Total height Highest p	379 mm	Drehbar Rotatable	1
Matchcode Matchcode	S215257122K98CX	Gesamthöhe niedrigs Total height lowest po	257 mm	Standrohrlänge Standpipe length	210 mm		
Bezeichnung 1 Designation 1	S 215 257 122 K 98	Hub Stroke	122 mm	Standrohrdurchmess Standpipe diameter	50 mm		
Artikelgruppe Article group	Standard Line Chro	Gewichtsgrenze Weight limit	140 kg	Aufbauhöhe ab Fuß M Build-up height from	159 mm		
Basismengeneinheit Base quantityunit	Stk	Klasse Class	4	Aufbauhöhe ab Fuß M Installation height fro	281 mm		
Menge Karton Quantity carton	10	Durchmesser Gaseinl Diameter gas unit	28 mm	Material	Stahlblech		
Menge Palette Quantity pallet	420	Konuslänge Gaseinhe Cone length gas unit	33 mm	Druck Pressure	320 N		
Gewicht Weight	1.09 kg	Konuslänge Cone length	98 mm	Höhenverstellbar Heightadjustable	1		

S 215 257 122 K 98 C X ESD

ID 205673

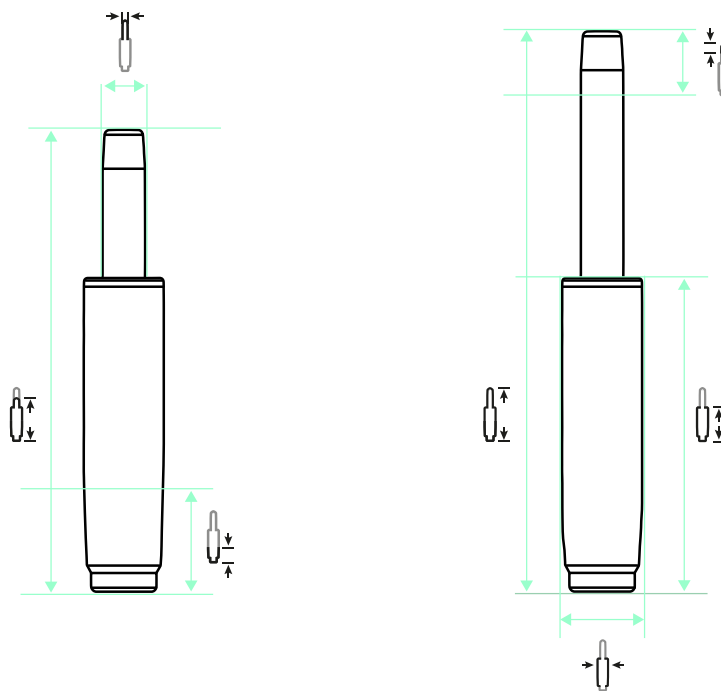

 122 mm |
  379 mm |
  257 mm |
  210 mm |
  98 mm |
  33 mm |
  50 mm |
  28 mm |
  320 N

ZUBEHÖR ACCESSORIES



AD 38 / 50



AD 40 / 50



ÜS-Rohr 183



ÜS-Rohr 244



ÜS-Rohr 298

EMPFEHLUNGEN RECOMMENDATIONS



STELLAR 690 Middle 5 P



STELLAR 690 Middle 5 S



North 1 Alu-Mechanik P



Threesixty