

# S 370 431 252 K 50 C X ESD

ID 205674

Technisches Datenblatt  
Technical data sheet



## Spezifikationen Specifications

ID ID	<b>205674</b>	Farbe Colour	<b>chrom</b>	Gesamthöhe Höchste Total height Highest p	<b>683 mm</b>	Drehbar Rotatable	<b>1</b>
Matchcode Matchcode	<b>S370431252K50CXI</b>	Gesamthöhe niedrigs Total height lowest po	<b>431 mm</b>	Standrohrlänge Standpipe length	<b>370 mm</b>		
Bezeichnung 1 Designation 1	<b>S 370 431 252 K 50</b>	Hub Stroke	<b>252 mm</b>	Standrohrdurchmess Standpipe diameter	<b>50 mm</b>		
Artikelgruppe Article group	<b>Standard Line Chro</b>	Gewichtsgrenze Weight limit	<b>140 kg</b>	Aufbauhöhe ab Fuß M Build-up height from	<b>381 mm</b>		
Basismengeneinheit Base quantityunit	<b>Stk</b>	Klasse Class	<b>4</b>	Aufbauhöhe ab Fuß M Installation height fro	<b>633 mm</b>		
Menge Karton Quantity carton	<b>20</b>	Durchmesser Gaseinl Diameter gas unit	<b>28 mm</b>	Material	<b>Stahlblech</b>		
Menge Palette Quantity pallet	<b>600</b>	Konuslänge Gaseinhe Cone length gas unit	<b>33 mm</b>	Druck Pressure	<b>320 N</b>		
Gewicht Weight	<b>1.79 kg</b>	Konuslänge Cone length	<b>50 mm</b>	Höhenverstellbar Heightadjustable	<b>1</b>		

# S 370 431 252 K 50 C X ESD

ID 205674

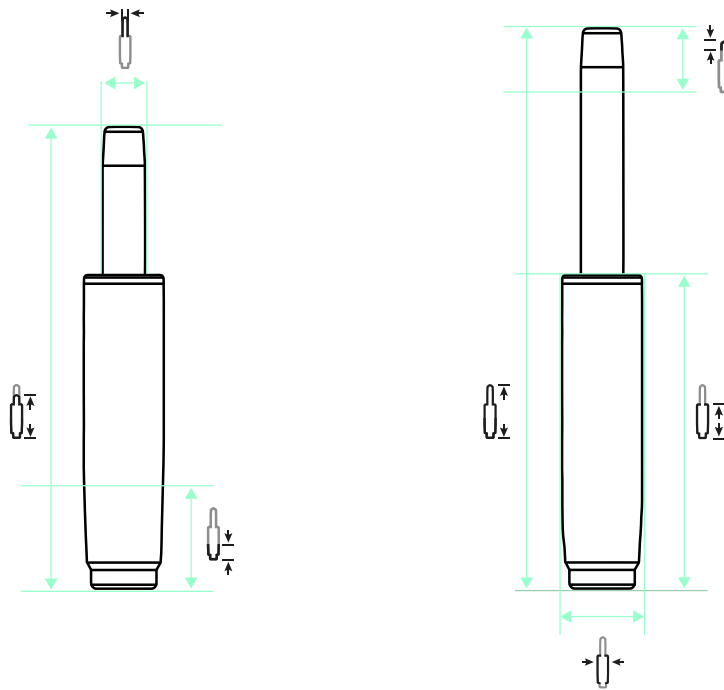

252 mm |
 683 mm |
 431 mm |
 370 mm |
 50 mm |
 33 mm |
 50 mm |
 28 mm |
 320 N

## ZUBEHÖR ACCESSORIES



AD 38 / 50



AD 40 / 50



ÜS-Rohr 183



ÜS-Rohr 244



ÜS-Rohr 298

## EMPFEHLUNGEN RECOMMENDATIONS



STELLAR 690 Middle 5 P



STELLAR 690 Middle 5 S



North 1 Alu-Mechanik P



Threesixty