

S 385 453 252 K 100 C X ESD

ID 205675

Technisches Datenblatt
Technical data sheet



Spezifikationen Specifications

ID ID	205675	Farbe Colour	chrom	Gesamthöhe Höchste Total height Highest p	705 mm	Drehbar Rotatable	1
Matchcode Matchcode	S385453252K100CX	Gesamthöhe niedrigs Total height lowest po	453 mm	Standrohrlänge Standpipe length	385 mm		
Bezeichnung 1 Designation 1	S 385 453 252 K 100	Hub Stroke	252 mm	Standrohrdurchmess Standpipe diameter	50 mm		
Artikelgruppe Article group	Standard Line Chro	Gewichtsgrenze Weight limit	140 kg	Aufbauhöhe ab Fuß M Build-up height from	353 mm		
Basismengeneinheit Base quantityunit	Stk	Klasse Class	4	Aufbauhöhe ab Fuß M Installation height fro	605 mm		
Menge Karton Quantity carton	10	Durchmesser Gaseinl Diameter gas unit	28 mm	Material	Stahlblech		
Menge Palette Quantity pallet	420	Konuslänge Gaseinhe Cone length gas unit	33 mm	Druck Pressure	320 N		
Gewicht Weight	1.85 kg	Konuslänge Cone length	100 mm	Höhenverstellbar Heightadjustable	1		

S 385 453 252 K 100 C X ESD

ID 205675

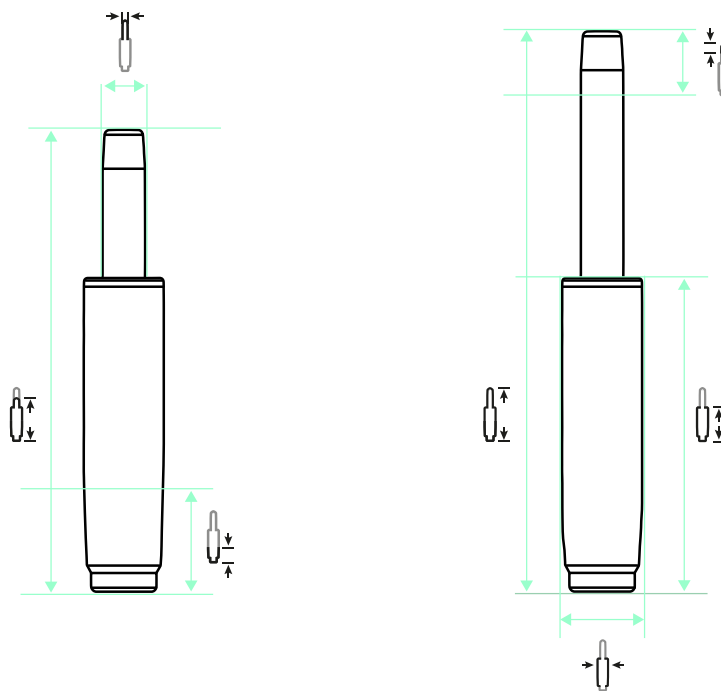

252 mm |
 705 mm |
 453 mm |
 385 mm |
 100 mm |
 33 mm |
 50 mm |
 28 mm |
 320 N

ZUBEHÖR ACCESSORIES



AD 38 / 50



AD 40 / 50



ÜS-Rohr 183



ÜS-Rohr 244



ÜS-Rohr 298

EMPFEHLUNGEN RECOMMENDATIONS



STELLAR 690 Middle 5 P



STELLAR 690 Middle 5 S



North 1 Alu-Mechanik P



Threesixty