

STELLAR 708 LOW 5 KU

ID 205904

Technisches Datenblatt
Technical data sheet



Spezifikationen Specifications

ID ID	205904	Material Material	Kunststoff	Innendurchmesser Inner diameter	685 mm
Matchcode Matchcode	STELLAR708LOW5KU	Außendurchmesser Outer diameter	708 mm	Durchmesser Rollenaufnahme Diameter of roller holder	11x22 mm
Bezeichnung 1 Designation 1	STELLAR 708 Low 5 KU	Höhe Height	70 mm	Hals Neck	23 mm
Artikelgruppe Article group	Stellar Low KU	Anzahl Füße Number of feet	5	Oberfläche Surface	Feinstruktur
Basismengeneinheit Base quantity unit	Stk	BIFMA BIFMA	1	Rollenaufnahme Roller holder	11 mm
Gewicht Weight	0 kg	Farbe Colour	schwarz	Konus Cone	50 mm

STELLAR 708 LOW 5 KU

ID 205904

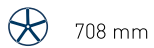
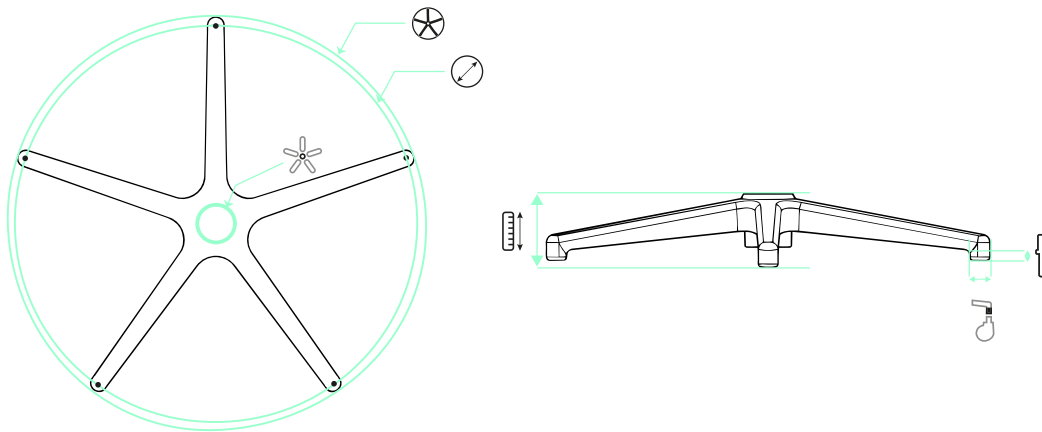

708 mm



685 mm



11x22 mm



23 mm

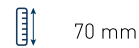

70 mm



50 mm

EMPFEHLUNGEN RECOMMENDATIONS



S 235 290 132 K 70 C X



S 235 290 132 K 70 S X



155 H16 50 30 3 P U



166 60 30 3 PU



Tendo P