

STELLAR 690 HIGH 4 P

ID 205880

Technisches Datenblatt
Technical data sheet



Spezifikationen Specifications

ID ID	205880	Außendurchmesser Outer diameter	690 mm	Hals Neck	22 mm
Matchcode Matchcode	stellar690high4p	Höhe Height	320 mm	Oberfläche Surface	Poliert
Bezeichnung 1 Designation 1	STELLAR 690 High 4 P	Anzahl Füße Number of feet	4	Rollenaufnahme Roller holder	11 mm
Artikelgruppe Article group	Stellar High	BIFMA BIFMA	1	Konus Cone	50 mm
Basismengeneinheit Base quantity unit	Stk	Farbe Colour	poliert	Höhe Dom Height dome	mm
Gewicht Weight	1.3 kg	Innendurchmesser Inner diameter	668 mm	Gewichtsgrenze Weight limit	kg
Material Material	Aluminium	Durchmesser Rollenaufnahme Diameter of roller holder	11x22 mm		

STELLAR 690 HIGH 4 P

ID 205880

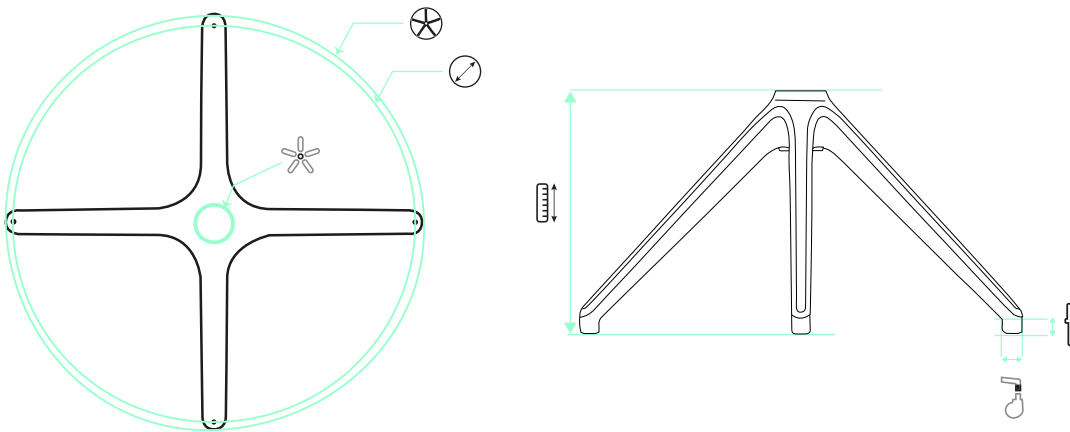

690 mm



668 mm



11x22 mm



22 mm



320 mm



50 mm

EMPFEHLUNGEN RECOMMENDATIONS



SKD 148 C X



SKD 148 S X



155 H16 50 30 3 P U



166 60 30 3 PU



Tendo P