

# FLAKE 498 KU

ID 205856

Technisches Datenblatt  
Technical data sheet



## Spezifikationen Specifications

ID ID	<b>205856</b>	Gewicht Weight	<b>0.879 kg</b>	Innendurchmesser Inner diameter	<b>470 mm</b>	Gewichtsgrenze Weight limit	<b>kg</b>
Matchcode Matchcode	<b>Flake498KU</b>	Material Material	<b>Kunststoff</b>	Durchmesser Roller Diameter of roller holder	<b>11x22 mm</b>		
Bezeichnung 1 Designation 1	<b>Flake 498 KU</b>	Außendurchmesser Outer diameter	<b>498 mm</b>	Hals Neck	<b>28 mm</b>		
Artikelgruppe Article group	<b>Flake KU</b>	Höhe Height	<b>80 mm</b>	Oberfläche Surface	<b>Feinstruktur</b>		
Basismengeneinheit Base quantity unit	<b>Stk</b>	Anzahl Füße Number of feet	<b>5</b>	Rollenaufnahme Roller holder	<b>11 mm</b>		
Menge Karton Quantity carton	<b>7</b>	BIFMA BIFMA	<b>1</b>	Konus Cone	<b>50 mm</b>		
Menge Palette Quantity pallet	<b>168</b>	Farbe Colour	<b>schwarz</b>	Höhe Dom Height dome	<b>mm</b>		

# FLAKE 498 KU

ID 205856

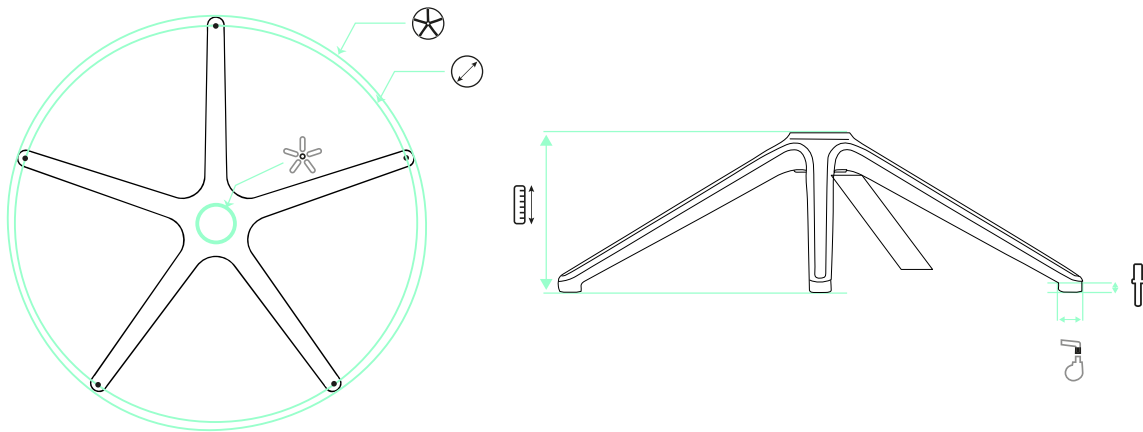

498 mm

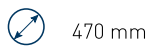

470 mm



11x22 mm



28 mm

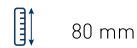

80 mm



50 mm

## EMPFEHLUNGEN RECOMMENDATIONS



S 235 290 132 K 70 C X



S 235 290 132 K 70 S X



155 H28 65 30 3 PU



166 60 30 3 PU