

STELLAR 610 LOW 5 P

ID 206119

Technisches Datenblatt
Technical data sheet



Spezifikationen Specifications

ID ID	206119	Außendurchmesser Outer diameter	612 mm	Hals Neck	23 mm
Matchcode Matchcode	STELLAR610Low5P	Höhe Height	70 mm	Oberfläche Surface	Poliert
Bezeichnung 1 Designation 1	STELLAR 610 Low 5 P	Anzahl Füße Number of feet	5	Rollenaufnahme Roller holder	11 mm
Artikelgruppe Article group	Stellar Low 5	BIFMA BIFMA	1	Konus Cone	50 mm
Basismengeneinheit Base quantity unit	Stk	Farbe Colour	poliert	Höhe Dom Height dome	mm
Gewicht Weight	kg	Innendurchmesser Inner diameter	558 mm	Gewichtsgrenze Weight limit	kg
Material Material	Aluminium	Durchmesser Rollenaufnahme Diameter of roller holder	11x22 mm		

STELLAR 610 LOW 5 P

ID 206119

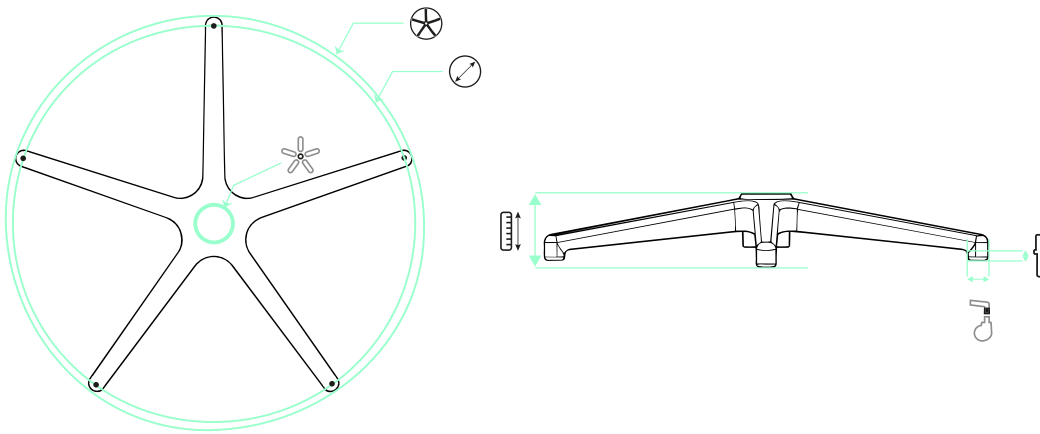

612 mm



558 mm



11x22 mm



23 mm



70 mm



50 mm

EMPFEHLUNGEN RECOMMENDATIONS



S 235 290 132 K 70 C X



S 235 290 132 K 70 S X



155 H16 50 30 3 P U



166 60 30 3 PU



Tendo P