

AF 50 P

ID 100032

Technisches Datenblatt
Technical data sheet



Spezifikationen *Specifications*

ID <i>ID</i>	100032	Gewicht <i>Weight</i>	1.782 kg	Innendurchmesser <i>Inner diameter</i>	645 mm
Matchcode <i>Matchcode</i>	AF50P	Material <i>Material</i>	Aluminium	Durchmesser Rollenaufnahme <i>Diameter of roller holder</i>	11x22 mm
Bezeichnung 1 <i>Designation 1</i>	AF 50 P	Außendurchmesser <i>Outer diameter</i>	669 mm	Hals <i>Neck</i>	20 mm
Artikelgruppe <i>Article group</i>	AF50	Höhe <i>Height</i>	140 mm	Oberfläche <i>Surface</i>	Poliert
Basismengeneinheit <i>Base quantityunit</i>	Stk	Anzahl Füße <i>Number of feet</i>	5	Rollenaufnahme <i>Roller holder</i>	11 mm
Menge Karton <i>Quantity carton</i>	6	BIFMA <i>BIFMA</i>	1	Konus <i>Cone</i>	50 mm
Menge Palette <i>Quantity pallet</i>	120	Farbe <i>Colour</i>	poliert		

AF 50 P

ID 100032

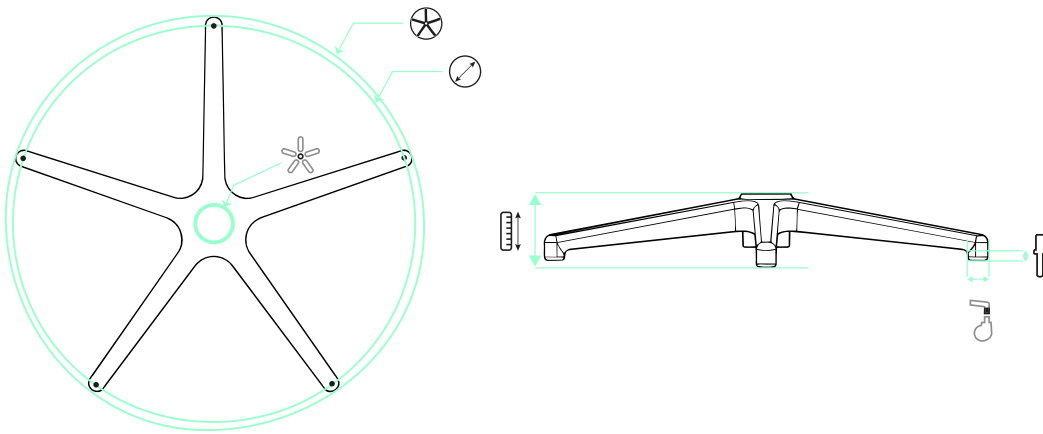

669 mm



645 mm



11x22 mm



20 mm



140 mm



50 mm

EMPFEHLUNGEN RECOMMENDATIONS



S 235 290 132 K 70 C X



S 235 290 132 K 70 S X



155 50 30 3 P U T



166 60 30 3 PU