

AF 290 P

ID 102724

Technisches Datenblatt
Technical data sheet



Spezifikationen *Specifications*

ID <i>ID</i>	102724	Material <i>Material</i>	Aluminium	Innendurchmesser <i>Inner diameter</i>	620 mm
Matchcode <i>Matchcode</i>	AF290P	Außendurchmesser <i>Outer diameter</i>	640 mm	Durchmesser Rollenaufnahme <i>Diameter of roller holder</i>	11x22 mm
Bezeichnung 1 <i>Designation 1</i>	AF 290 P	Höhe <i>Height</i>	61 mm	Hals <i>Neck</i>	20 mm
Artikelgruppe <i>Article group</i>	AF290 / 295	Anzahl Füße <i>Number of feet</i>	5	Oberfläche <i>Surface</i>	Poliert
Basismengeneinheit <i>Base quantityunit</i>	Stk	BIFMA <i>BIFMA</i>	1	Rollenaufnahme <i>Roller holder</i>	11 mm
Gewicht <i>Weight</i>	1.861 kg	Farbe <i>Colour</i>	poliert	Konus <i>Cone</i>	50 mm

AF 290 P

ID 102724

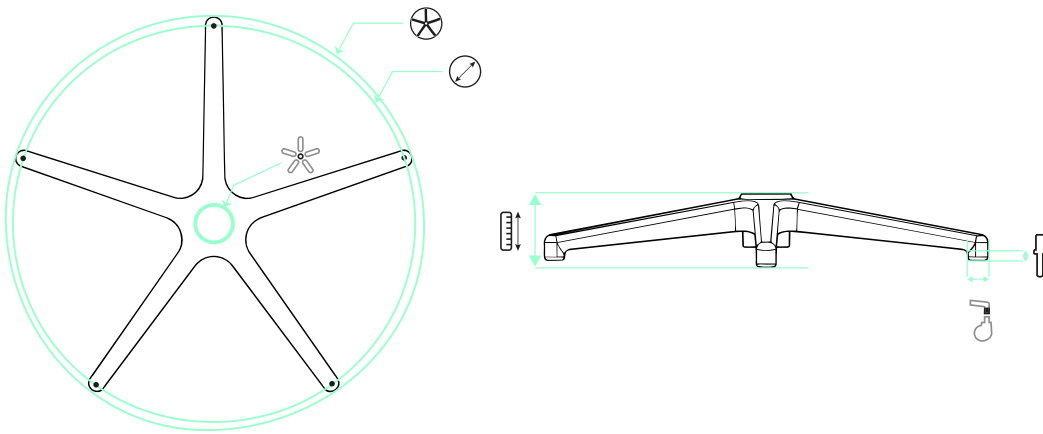

640 mm



620 mm



11x22 mm



20 mm



61 mm



50 mm

EMPFEHLUNGEN RECOMMENDATIONS



S 235 290 132 K 70 C X



S 235 290 132 K 70 S X



155 50 30 3 P U T



166 60 30 3 PU