

S 40 230 290 132 K 100 C X

ID 103326

Technisches Datenblatt
Technical data sheet



Spezifikationen Specifications

ID ID	103326	Gesamthöhe niedrigs Total height lowest p	290 mm	Standrohrlänge Standpipe length	230 mm	Drehbar Rotatable	1
Matchcode Matchcode	S40230290132K100	Hub Stroke	132 mm	Standrohrdurchmess Standpipe diameter	40 mm		
Bezeichnung 1 Designation 1	S 40 230 290 132 K	Gewichtsgrenze Weight limit	140 kg	Aufbauhöhe ab Fuß M Build-up height from	190 mm		
Artikelgruppe Article group	Thin Line 40mm	Klasse Class	4	Aufbauhöhe ab Fuß M Installation height fro	322 mm		
Basismengeneinheit Base quantityunit	Stk	Durchmesser Gaseinl Diameter gas unit	28 mm	Material Material	Stahlblech		
Menge Karton Quantity carton	20	Konuslänge Gaseinhe Cone length gas unit	33 mm	Druck Pressure	320 N		
Gewicht Weight	1.135 kg	Konuslänge Cone length	100 mm	Anschraubbild Bolting pattern	-		
Farbe Colour	chrom	Gesamthöhe Höchste Total height Highest p	422 mm	Höhenverstellbar Heightadjustable	1		

S 40 230 290 132 K 100 C X

ID 103326

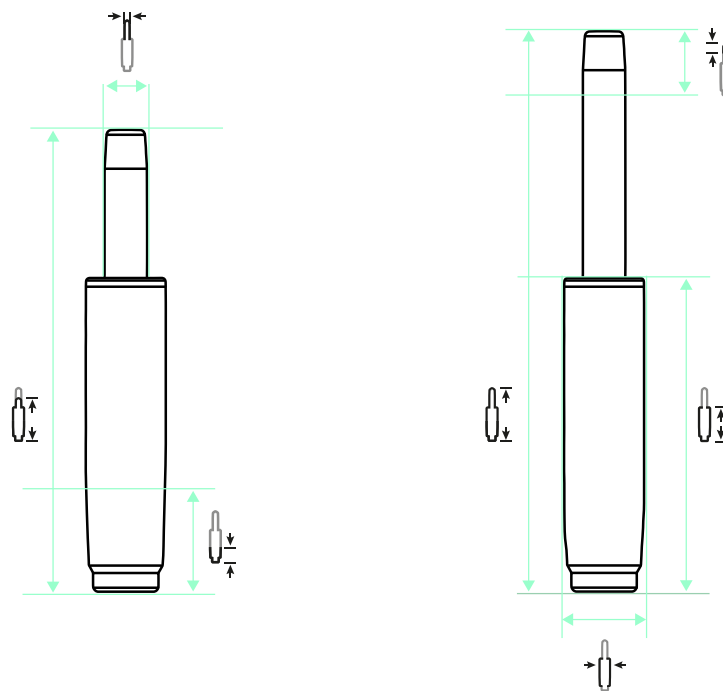

132 mm |
 422 mm |
 290 mm |
 230 mm |
 100 mm |
 33 mm |
 40 mm |
 28 mm |
 320 N

EMPFEHLUNGEN RECOMMENDATIONS



AF 294 K40 P



North 1 Alu-Mechanik P



Threesixty