

# LONDON 725 P

ID 103656

Technisches Datenblatt  
*Technical data sheet*



## Spezifikationen *Specifications*

ID <i>ID</i>	<b>103656</b>	Gewicht <i>Weight</i>	<b>2.15 kg</b>	Innendurchmesser <i>Inner diameter</i>	<b>700 mm</b>
Matchcode <i>Matchcode</i>	<b>London725P</b>	Material <i>Material</i>	<b>Aluminium</b>	Durchmesser Rollenaufnahm <i>Diameter of roller holder</i>	<b>11x22 mm</b>
Bezeichnung 1 <i>Designation 1</i>	<b>London 725 P</b>	Außendurchmesser <i>Outer diameter</i>	<b>725 mm</b>	Hals <i>Neck</i>	<b>22 mm</b>
Artikelgruppe <i>Article group</i>	<b>London 5</b>	Höhe <i>Height</i>	<b>80 mm</b>	Oberfläche <i>Surface</i>	<b>Poliert</b>
Basismengeneinheit <i>Base quantityunit</i>	<b>Stk</b>	Anzahl Füße <i>Number of feet</i>	<b>5</b>	Rollenaufnahme <i>Roller holder</i>	<b>11 mm</b>
Menge Karton <i>Quantity carton</i>	<b>8</b>	BIFMA <i>BIFMA</i>	<b>1</b>	Konus <i>Cone</i>	<b>50 mm</b>
Menge Palette <i>Quantity pallet</i>	<b>96</b>	Farbe <i>Colour</i>	<b>poliert</b>		

# LONDON 725 P

ID 103656

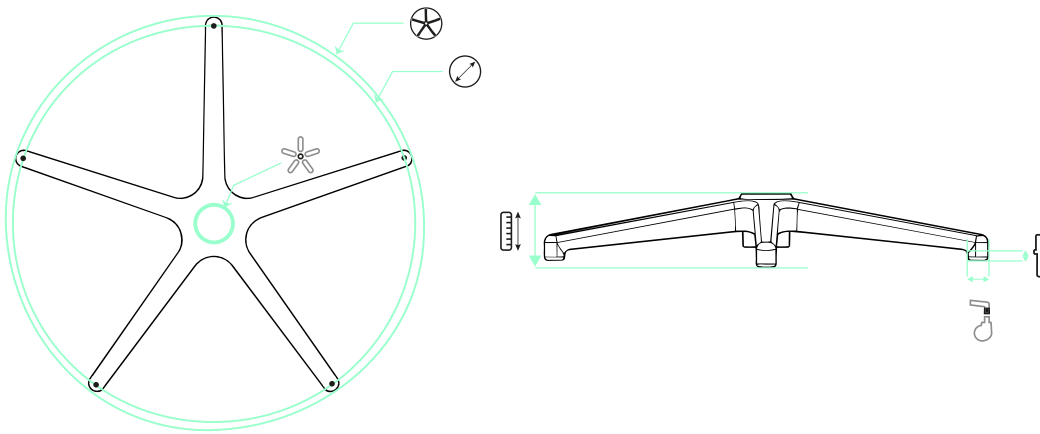

725 mm



700 mm



11x22 mm



22 mm



80 mm



50 mm

## EMPFEHLUNGEN RECOMMENDATIONS



S 235 290 132 K 70 C X



S 235 290 132 K 70 S X



155 50 30 3 P U T



166 60 30 3 PU