

LONDON 520 P

ID 105474

Technisches Datenblatt
Technical data sheet



Spezifikationen *Specifications*

ID <i>ID</i>	105474	Material <i>Material</i>	Aluminium	Innendurchmesser <i>Inner diameter</i>	496 mm
Matchcode <i>Matchcode</i>	London520P	Außendurchmesser <i>Outer diameter</i>	520 mm	Durchmesser Rollenaufnahm <i>Diameter of roller holder</i>	11x22 mm
Bezeichnung 1 <i>Designation 1</i>	London 520 P	Höhe <i>Height</i>	65 mm	Hals <i>Neck</i>	22 mm
Artikelgruppe <i>Article group</i>	London 5	Anzahl Füße <i>Number of feet</i>	5	Oberfläche <i>Surface</i>	Poliert
Basismengeneinheit <i>Base quantityunit</i>	Stk	BIFMA <i>BIFMA</i>	1	Rollenaufnahme <i>Roller holder</i>	11 mm
Gewicht <i>Weight</i>	1.15 kg	Farbe <i>Colour</i>	poliert	Konus <i>Cone</i>	50 mm

LONDON 520 P

ID 105474

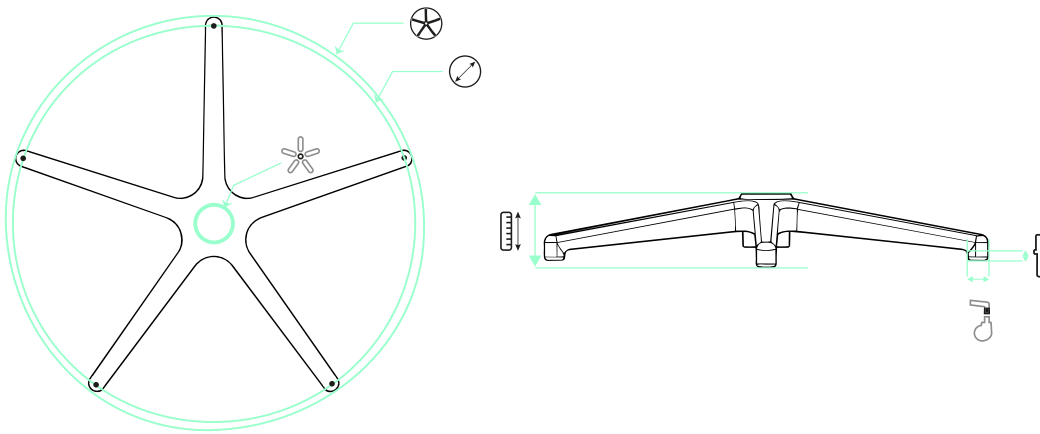

520 mm



496 mm



11x22 mm



22 mm



65 mm



50 mm

EMPFEHLUNGEN RECOMMENDATIONS



S 235 290 132 K 70 C X



S 235 290 132 K 70 S X



155 50 30 3 P U T



166 60 30 3 PU