

# KF 480 S

ID 200702

Technisches Datenblatt  
*Technical data sheet*



## Spezifikationen *Specifications*

ID <i>ID</i>	<b>200702</b>	Gewicht <i>Weight</i>	<b>1.072 kg</b>	Innendurchmesser <i>Inner diameter</i>	<b>447 mm</b>
Matchcode <i>Matchcode</i>	<b>KF480S</b>	Material <i>Material</i>	<b>Kunststoff</b>	Durchmesser Rollenaufnahme <i>Diameter of roller holder</i>	<b>11x22 mm</b>
Bezeichnung 1 <i>Designation 1</i>	<b>KF 480 S</b>	Außendurchmesser <i>Outer diameter</i>	<b>487 mm</b>	Hals <i>Neck</i>	<b>40 mm</b>
Artikelgruppe <i>Article group</i>	<b>KF480</b>	Höhe <i>Height</i>	<b>70 mm</b>	Oberfläche <i>Surface</i>	<b>Feinstruktur</b>
Basismengeneinheit <i>Base quantityunit</i>	<b>Stk</b>	Anzahl Füße <i>Number of feet</i>	<b>5</b>	Rollenaufnahme <i>Roller holder</i>	<b>11 mm</b>
Menge Karton <i>Quantity carton</i>	<b>5</b>	BIFMA <i>BIFMA</i>	<b>1</b>	Konus <i>Cone</i>	<b>50 mm</b>
Menge Palette <i>Quantity pallet</i>	<b>150</b>	Farbe <i>Colour</i>	<b>schwarz</b>		

# KF 480 S

ID 200702

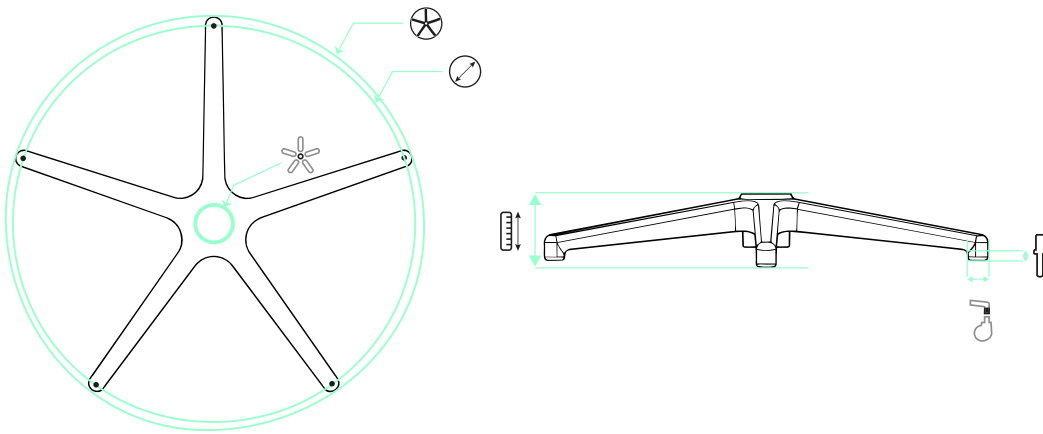

487 mm

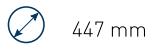

447 mm

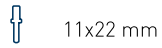

11x22 mm



40 mm



70 mm



50 mm

## EMPFEHLUNGEN RECOMMENDATIONS



S 235 290 132 K 70 C X



S 235 290 132 K 70 S X



155 H38 50 30 3 P U



166 60 30 3 PU