

KF 100 S

ID 200869

Technisches Datenblatt
Technical data sheet



Spezifikationen Specifications

ID <i>ID</i>	200869	Material <i>Material</i>	Kunststoff	Innendurchmesser <i>Inner diameter</i>	562 mm
Matchcode <i>Matchcode</i>	KF100S	Außendurchmesser <i>Outer diameter</i>	600 mm	Durchmesser Rollenaufnahme <i>Diameter of roller holder</i>	11x22 mm
Bezeichnung 1 <i>Designation 1</i>	KF 100 S	Höhe <i>Height</i>	73 mm	Hals <i>Neck</i>	42 mm
Artikelgruppe <i>Article group</i>	KF100 / 104 / 108	Anzahl Füße <i>Number of feet</i>	5	Rollenaufnahme <i>Roller holder</i>	11 mm
Basismengeneinheit <i>Base quantityunit</i>	Stk	BIFMA <i>BIFMA</i>	1	Konus <i>Cone</i>	50 mm
Gewicht <i>Weight</i>	1.382 kg	Farbe <i>Colour</i>	schwarz		

KF 100 S

ID 200869

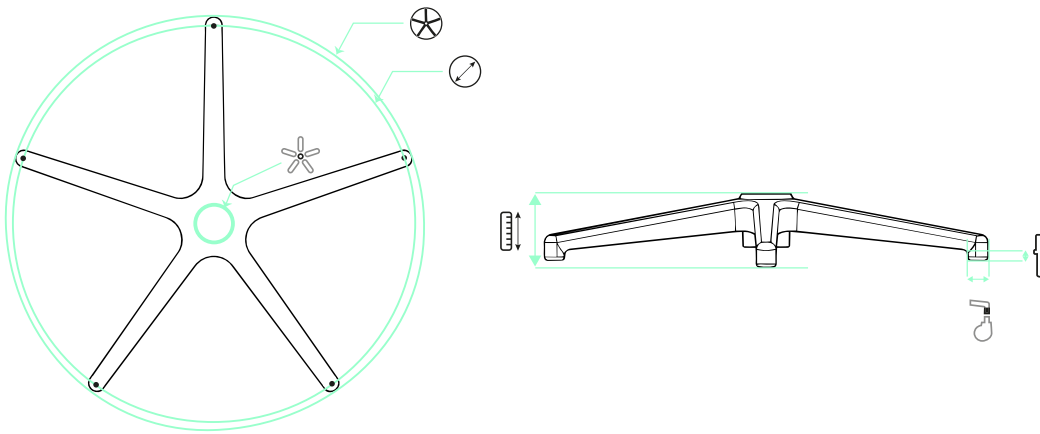

600 mm



562 mm



11x22 mm



42 mm



73 mm



50 mm

EMPFEHLUNGEN RECOMMENDATIONS



S 235 290 132 K 70 C X



S 235 290 132 K 70 S X



155 50 30 3 P U T



166 60 30 3 PU