

BERLIN 608 P

ID 201153

Technisches Datenblatt
Technical data sheet



Spezifikationen Specifications

ID ID	201153	Gewicht Weight	1.51 kg	Innendurchmesser Inner diameter	580 mm
Matchcode Matchcode	Berlin608P	Material Material	Aluminium	Durchmesser Rollenaufnahme Diameter of roller holder	11x22 mm
Bezeichnung 1 Designation 1	Berlin 608 P	Außendurchmesser Outer diameter	608 mm	Hals Neck	28 mm
Artikelgruppe Article group	Berlin 5	Höhe Height	50 mm	Oberfläche Surface	Poliert
Basismengeneinheit Base quantityunit	Stk	Anzahl Füße Number of feet	5	Rollenaufnahme Roller holder	11.2 mm
Menge Karton Quantity carton	6	BIFMA BIFMA	1	Konus Cone	50 mm
Menge Palette Quantity pallet	120	Farbe Colour	poliert		

BERLIN 608 P

ID 201153

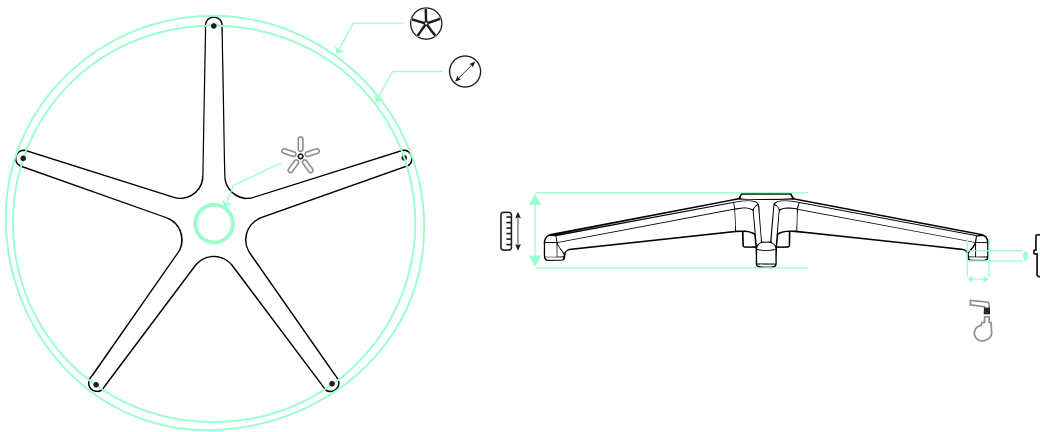

608 mm



580 mm



11x22 mm



28 mm



50 mm



50 mm

EMPFEHLUNGEN RECOMMENDATIONS



S 235 290 132 K 70 C X



S 235 290 132 K 70 S X



155 H28 65 30 3 PU



166 60 30 3 PU