

S 285 350 195 K 100 S X

ID 201574

Technisches Datenblatt
Technical data sheet



Spezifikationen Specifications

ID ID	201574	Farbe Colour	schwarz	Gesamthöhe Höchste Total height Highest p	545 mm	Drehbar Rotatable	1
Matchcode Matchcode	S285350195K100SX	Gesamthöhe niedrigs Total height lowest p	350 mm	Standrohrlänge Standpipe length	285 mm		
Bezeichnung 1 Designation 1	S 285 350 195 K 100	Hub Stroke	195 mm	Standrohrdurchmess Standpipe diameter	50 mm		
Artikelgruppe Article group	Standard Line Schw	Gewichtsgrenze Weight limit	140 kg	Aufbauhöhe ab Fuß M Build-up height from	250 mm		
Basismengeneinheit Base quantityunit	Stk	Klasse Class	4	Aufbauhöhe ab Fuß M Installation height fro	445 mm		
Menge Karton Quantity carton	10	Durchmesser Gaseinl Diameter gas unit	28 mm	Material	Stahlblech		
Menge Palette Quantity pallet	420	Konuslänge Gaseinhe Cone length gas unit	33 mm	Druck Pressure	320 N		
Gewicht Weight	1.424 kg	Konuslänge Cone length	100 mm	Höhenverstellbar Heightadjustable	1		

S 285 350 195 K 100 S X

ID 201574

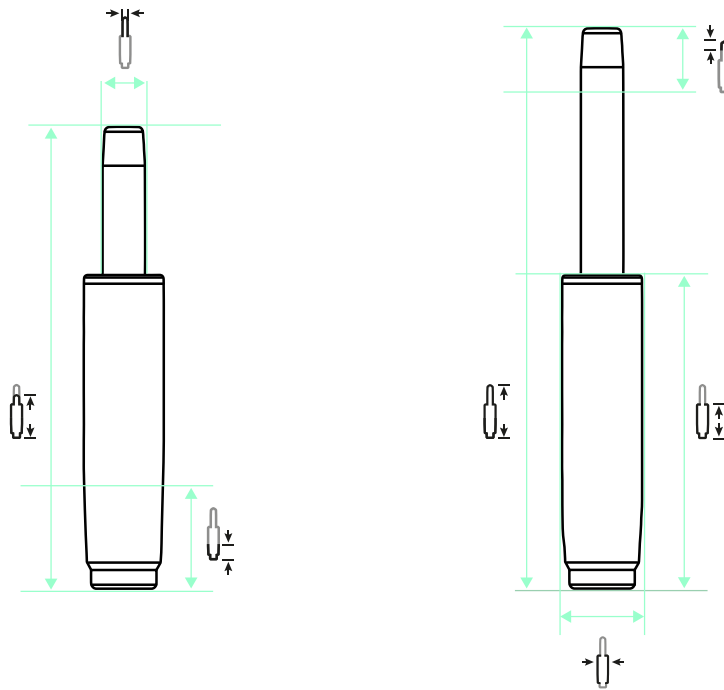

195 mm |
 545 mm |
 350 mm |
 285 mm |
 100 mm |
 33 mm |
 50 mm |
 28 mm |
 320 N

ZUBEHÖR ACCESSORIES



AD 38 / 50



AD 40 / 50



ÜS-Rohr 183



ÜS-Rohr 244



ÜS-Rohr 298

EMPFEHLUNGEN RECOMMENDATIONS



STELLAR 690 Middle 5 P



STELLAR 690 Middle 5 S



North 1 Alu-Mechanik P



Threesixty