

# S 235 286 132 K 125 S X

ID 201667

Technisches Datenblatt  
Technical data sheet



## Spezifikationen Specifications

ID ID	<b>201667</b>	Gesamthöhe niedrigste Position Total height lowest position	<b>286 mm</b>	Standrohrlänge Standpipe length	<b>235 mm</b>
Matchcode Matchcode	<b>S235286132K125SX300</b>	Hub Stroke	<b>132 mm</b>	Standrohrdurchmesser Standpipe diameter	<b>50 mm</b>
Bezeichnung 1 Designation 1	<b>S 235 286 132 K 125 S X</b>	Gewichtsgrenze Weight limit	<b>140 kg</b>	Aufbauhöhe ab Fuß Min. Build-up height from foot	<b>161 mm</b>
Artikelgruppe Article group	<b>Standard Line Schwarz</b>	Klasse Class	<b>4</b>	Aufbauhöhe ab Fuß Max. Installation height from foot	<b>293 mm</b>
Basismengeneinheit Base quantity unit	<b>Stk</b>	Durchmesser Gaseinheit Diameter gas unit	<b>28 mm</b>	Material Material	<b>Stahlblech</b>
Menge Palette Quantity pallet	<b>500</b>	Konulänge Gaseinheit Cone length gas unit	<b>33 mm</b>	Druck Pressure	<b>320 N</b>
Gewicht Weight	<b>1.172 kg</b>	Konulänge Cone length	<b>125 mm</b>	Höhenverstellbar Heightadjustable	<b>1</b>
Farbe Colour	<b>schwarz</b>	Gesamthöhe Höchste Position Total height Highest position	<b>418 mm</b>	Drehbar Rotatable	<b>1</b>

# S 235 286 132 K 125 S X

ID 201667

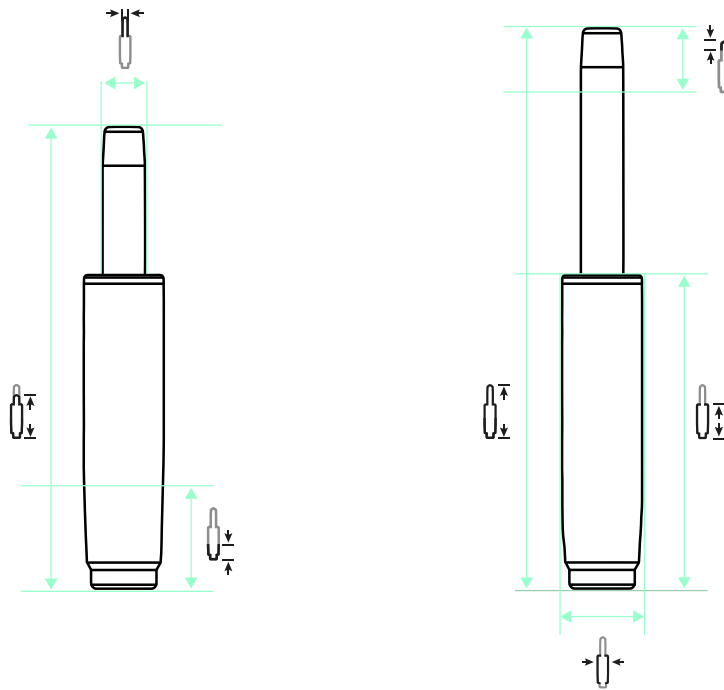

132 mm |
 418 mm |
 286 mm |
 235 mm |
 125 mm |
 33 mm |
 50 mm |
 28 mm |
 320 N

## ZUBEHÖR ACCESSORIES



AD 38 / 50



AD 40 / 50



ÜS-Rohr 183



ÜS-Rohr 244



ÜS-Rohr 298

## EMPFEHLUNGEN RECOMMENDATIONS



STELLAR 690 Middle 5 P



STELLAR 690 Middle 5 S



North 1 Alu-Mechanik P



Threesixty