

S 290 343 200 K 105 S X

ID 201668

Technisches Datenblatt

Technical data sheet



Spezifikationen Specifications

ID ID	201668	Farbe Colour	schwarz	Gesamthöhe Höchste Total height Highest p	535 mm	Drehbar Rotatable	1
Matchcode Matchcode	S290343200K105SX	Gesamthöhe niedrigs Total height lowest po	343 mm	Standrohrlänge Standpipe length	290 mm		
Bezeichnung 1 Designation 1	S 290 343 200 K 105	Hub Stroke	192 mm	Standrohrdurchmess Standpipe diameter	50 mm		
Artikelgruppe Article group	Standard Line Schw	Gewichtsgrenze Weight limit	140 kg	Aufbauhöhe ab Fuß M Build-up height from	mm		
Basismengeneinheit Base quantityunit	Stk	Klasse Class	4	Aufbauhöhe ab Fuß M Installation height fro	430 mm		
Menge Karton Quantity carton	10	Durchmesser Gaseinl Diameter gas unit	28 mm	Material	Stahlblech		
Menge Palette Quantity pallet	420	Konuslänge Gaseinhe Cone length gas unit	33 mm	Druck Pressure	320 N		
Gewicht Weight	1.417 kg	Konuslänge Cone length	105 mm	Höhenverstellbar Heightadjustable	1		

S 290 343 200 K 105 S X

ID 201668

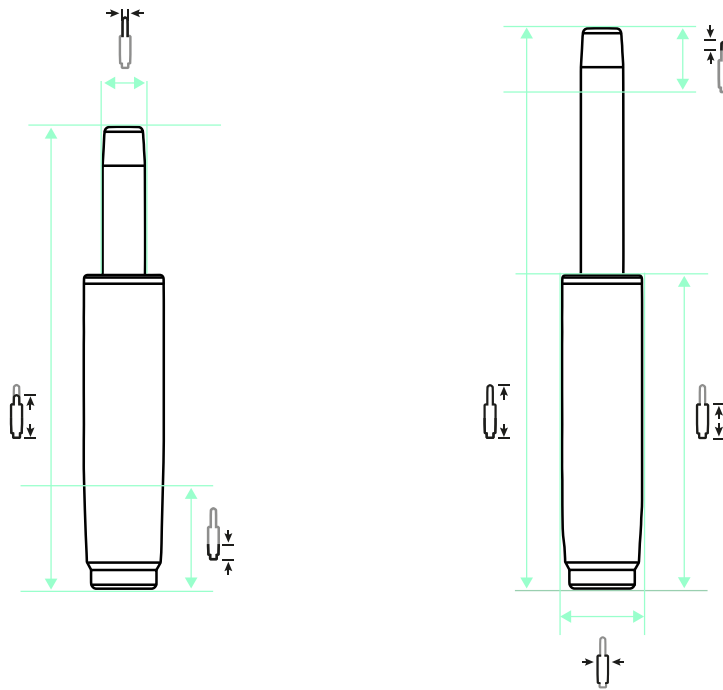

192 mm |
 535 mm |
 343 mm |
 290 mm |
 105 mm |
 33 mm |
 50 mm |
 28 mm |
 320 N

ZUBEHÖR ACCESSORIES



AD 38 / 50



AD 40 / 50



ÜS-Rohr 183



ÜS-Rohr 244



ÜS-Rohr 298

EMPFEHLUNGEN RECOMMENDATIONS



STELLAR 690 Middle 5 P



STELLAR 690 Middle 5 S



North 1 Alu-Mechanik P



Threesixty