

S 151 220 62 K 70 S X

ID 201685

Technisches Datenblatt
Technical data sheet



Spezifikationen Specifications

ID ID	201685	Farbe Colour	schwarz	Gesamthöhe Höchste Total height Highest p	282 mm	Drehbar Rotatable	1
Matchcode Matchcode	S15122062K70SX	Gesamthöhe niedrigs Total height lowest po	220 mm	Standrohrlänge Standpipe length	150 mm		
Bezeichnung 1 Designation 1	S 151 220 62 K 70 S X	Hub Stroke	62 mm	Standrohrdurchmess Standpipe diameter	50 mm		
Artikelgruppe Article group	Standard Line Schw	Gewichtsgrenze Weight limit	140 kg	Aufbauhöhe ab Fuß M Build-up height from	150 mm		
Basismengeneinheit Base quantityunit	Stk	Klasse Class	4	Aufbauhöhe ab Fuß M Installation height fro	212 mm		
Menge Karton Quantity carton	20	Durchmesser Gaseinl Diameter gas unit	28 mm	Material	Stahlblech		
Menge Palette Quantity pallet	600	Konuslänge Gaseinhe Cone length gas unit	33 mm	Druck Pressure	320 N		
Gewicht Weight	0.828 kg	Konuslänge Cone length	70 mm	Höhenverstellbar Heightadjustable	1		

S 151 220 62 K 70 S X

ID 201685

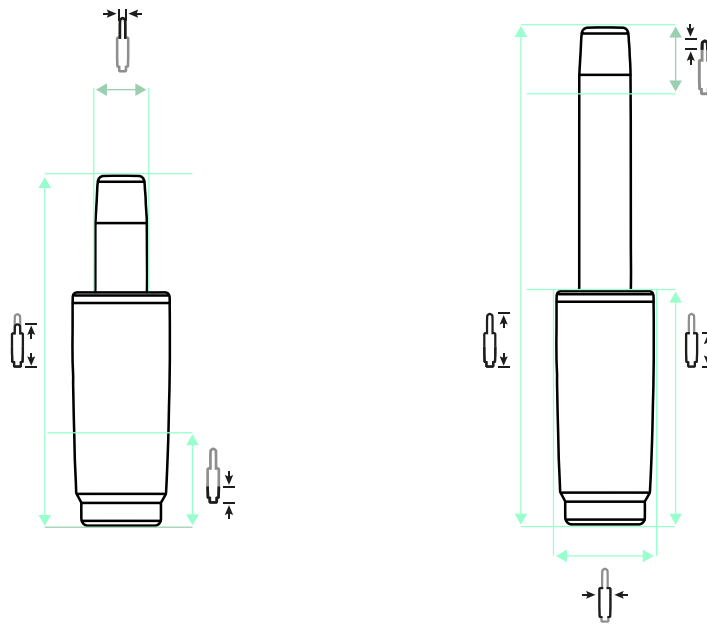

62 mm |
 282 mm |
 220 mm |
 150 mm |
 70 mm |
 33 mm |
 50 mm |
 28 mm |
 320 N

ZUBEHÖR ACCESSORIES



AD 38 / 50



AD 40 / 50



ÜS-Rohr 183



ÜS-Rohr 244



ÜS-Rohr 298

EMPFEHLUNGEN RECOMMENDATIONS



STELLAR 690 Middle 5 P



STELLAR 690 Middle 5 S



North 1 Alu-Mechanik P



Threesixty