

S 215 267 122 K 70 S X

ID 201749

Technisches Datenblatt
Technical data sheet



Spezifikationen Specifications

| | | | | | | | |
|---|--------------------|--|---------|--|------------|----------------------|---|
| ID ID | 201749 | Farbe Colour | schwarz | Gesamthöhe Höchste Total height Highest p | 389 mm | Drehbar Rotatable | 1 |
| Matchcode Matchcode | S215267122K70SX | Gesamthöhe niedrigs Total height lowest p | 267 mm | Standrohrlänge Standpipe length | 215 mm | | |
| Bezeichnung 1 Designation 1 | S 215 267 122 K 70 | Hub Stroke | 122 mm | Standrohrdurchmess Standpipe diameter | 50 mm | | |
| Artikelgruppe Article group | Standard Line Schw | Gewichtsgrenze Weight limit | 140 kg | Aufbauhöhe ab Fuß M Build-up height from | 197 mm | | |
| Basismengeneinheit Base quantityunit | Stk | Klasse Class | 4 | Aufbauhöhe ab Fuß M Installation height fro | 319 mm | | |
| Menge Karton Quantity carton | 20 | Durchmesser Gaseinl Diameter gas unit | 28 mm | Material | Stahlblech | | |
| Menge Palette Quantity pallet | 600 | Konuslänge Gaseinhe Cone length gas unit | 33 mm | Druck Pressure | 320 N | | |
| Gewicht Weight | 1.01 kg | Konuslänge Cone length | 70 mm | Höhenverstellbar Heightadjustable | 1 | | |

S 215 267 122 K 70 S X

ID 201749

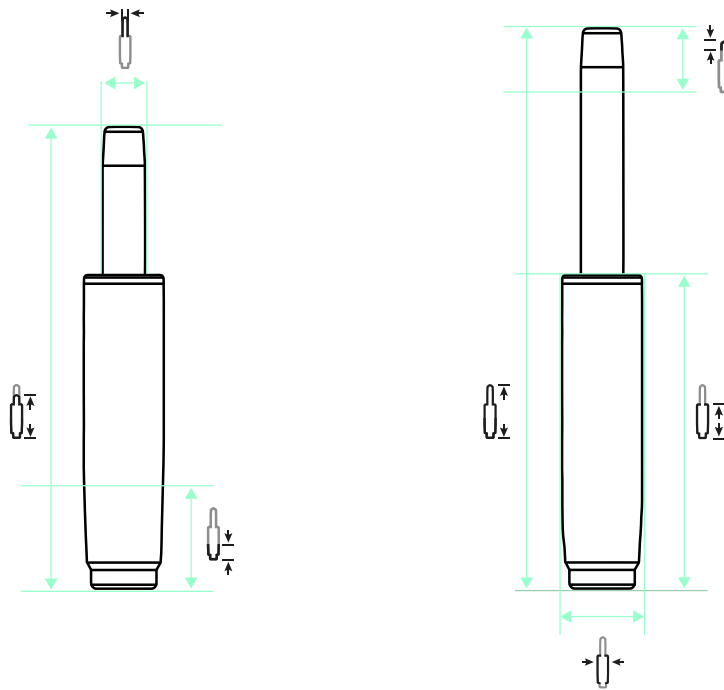

122 mm |
 389 mm |
 267 mm |
 215 mm |
 70 mm |
 33 mm |
 50 mm |
 28 mm |
 320 N

ZUBEHÖR ACCESSORIES



AD 38 / 50



AD 40 / 50



ÜS-Rohr 183



ÜS-Rohr 244



ÜS-Rohr 298

EMPFEHLUNGEN RECOMMENDATIONS



STELLAR 690 Middle 5 P



STELLAR 690 Middle 5 S



North 1 Alu-Mechanik P



Threesixty