

ND 210 261 112 K 145 S X

ID 201834

Technisches Datenblatt
Technical data sheet



Spezifikationen Specifications

ID ID	201834	Farbe Colour	schwarz	Gesamthöhe Höchst Total height Highest	373 mm	Höhenverstellbar Heightadjustable	1
Matchcode Matchcode	ND210261112K14	Gesamthöhe niedrig Total height lowest possible	261 mm	Standrohrlänge Standpipe length	210 mm		
Bezeichnung 1 Designation 1	ND 210 261 112 K	Hub Stroke	112 mm	Standrohrdurchmesser Standpipe diameter	50 mm		
Artikelgruppe Article group	Non Rotating	Gewichtsgrenze Weight limit	140 kg	Aufbauhöhe ab Fuß Build-up height from base	114 mm		
Basismengeneinheit Base quantity unit	Stk	Klasse Class	4	Aufbauhöhe ab Fuß Installation height from base	224 mm		
Menge Karton Quantity carton	20	Durchmesser Gaseinleit. Diameter gas unit	28 mm	Material Material	Stahlblech		
Menge Palette Quantity pallet	600	Konuslänge Gaseinleit. Cone length gas unit	33 mm	Druck Pressure	320 N		
Gewicht Weight	0.978 kg	Konuslänge Cone length	145 mm	Anschraubbild Bolting pattern	-		

ND 210 261 112 K 145 S X

ID 201834

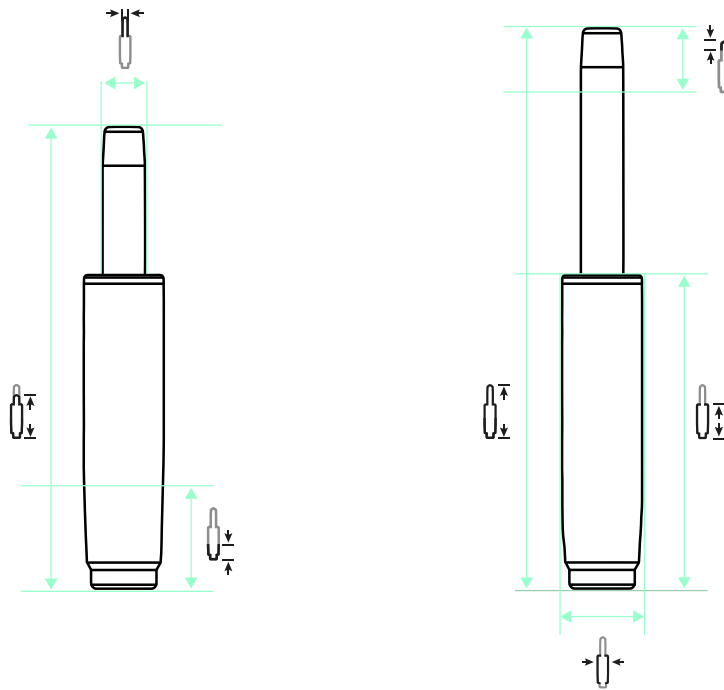

 112 mm |
  373 mm |
  261 mm |
  210 mm |
  145 mm |
  33 mm |
  50 mm |
  28 mm |
  320 N

ZUBEHÖR ACCESSORIES



AD 38 / 50



AD 40 / 50



ÜS-Rohr 183



ÜS-Rohr 244



ÜS-Rohr 298

EMPFEHLUNGEN RECOMMENDATIONS



STELLAR 690 Middle 5 P



STELLAR 690 Middle 5 S



North 1 Alu-Mechanik P



Threesixty