

ND 185 234 100 K 70 S X 200 N

ID 201874

Technisches Datenblatt
Technical data sheet



Spezifikationen Specifications

ID ID	201874	Farbe Colour	chrom	Gesamthöhe Höchst Total height Highest	334 mm	Höhenverstellbar Heightadjustable	1
Matchcode Matchcode	ND185234100K70	Gesamthöhe niedrig Total height lowest possible	234 mm	Standrohrlänge Standpipe length	185 mm		
Bezeichnung 1 Designation 1	ND 185 234 100 K	Hub Stroke	100 mm	Standrohrdurchmesser Standpipe diameter	50 mm		
Artikelgruppe Article group	Non Rotating	Gewichtsgrenze Weight limit	140 kg	Aufbauhöhe ab Fuß Build-up height from base	164 mm		
Basismengeneinheit Base quantityunit	Stk	Klasse Class	4	Aufbauhöhe ab Fuß Installation height from base	264 mm		
Menge Karton Quantity carton	20	Durchmesser Gaseinleitungsrohr Diameter gas inlet pipe	28 mm	Material Material	Stahlblech		
Menge Palette Quantity pallet	600	Konuslänge Gaseinleitungsrohr Cone length gas inlet pipe	33 mm	Druck Pressure	200 N		
Gewicht Weight	1.051 kg	Konuslänge Cone length	70 mm	Anschraubbild Bolting pattern	-		

ND 185 234 100 K 70 S X 200 N

ID 201874

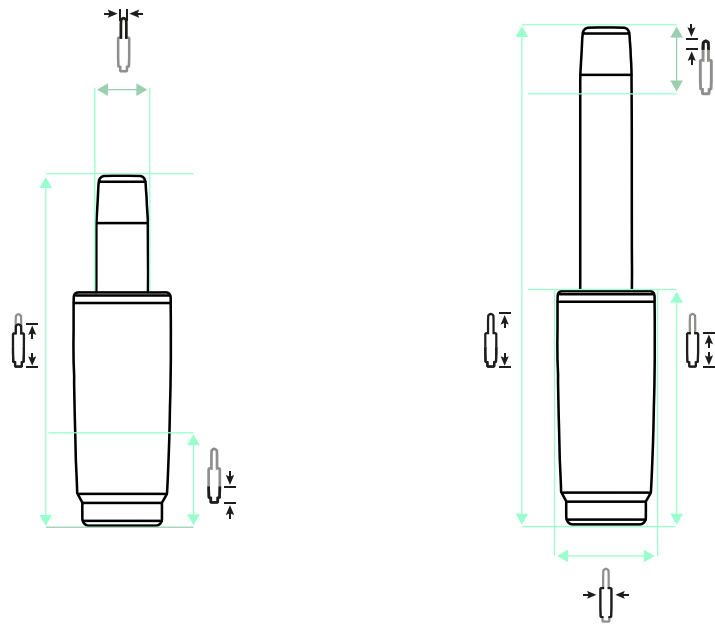

100 mm |
 334 mm |
 234 mm |
 185 mm |
 70 mm |
 33 mm |
 50 mm |
 28 mm |
 200 N

ZUBEHÖR ACCESSORIES



AD 38 / 50



AD 40 / 50



ÜS-Rohr 183



ÜS-Rohr 244



ÜS-Rohr 298

EMPFEHLUNGEN RECOMMENDATIONS



STELLAR 690 Middle 5 P



STELLAR 690 Middle 5 S



North 1 Alu-Mechanik P



Threesixty