

ND 235 290 132 K 70 C X

ID 201879

Technisches Datenblatt
Technical data sheet



Spezifikationen Specifications

ID ID	201879	Farbe Colour	chrom	Gesamthöhe Höchst Total height Highest	422 mm	Höhenverstellbar Heightadjustable	1
Matchcode Matchcode	ND235290132K70	Gesamthöhe niedrig Total height lowest possible	290 mm	Standrohrlänge Standpipe length	235 mm		
Bezeichnung 1 Designation 1	ND 235 290 132 K	Hub Stroke	132 mm	Standrohrdurchmesser Standpipe diameter	50 mm		
Artikelgruppe Article group	Non Rotating	Gewichtsgrenze Weight limit	140 kg	Aufbauhöhe ab Fuß Build-up height from base	220 mm		
Basismengeneinheit Base quantity unit	Stk	Klasse Class	4	Aufbauhöhe ab Fuß Installation height from base	352 mm		
Menge Karton Quantity carton	20	Durchmesser Gaseinleitungsrohr Diameter gas inlet pipe	28 mm	Material Material	Stahlblech		
Menge Palette Quantity pallet	600	Konuslänge Gaseinleitungsrohr Cone length gas inlet pipe	33 mm	Druck Pressure	320 N		
Gewicht Weight	1.3 kg	Konuslänge Cone length	70 mm	Anschraubbild Bolting pattern	-		

ND 235 290 132 K 70 C X

ID 201879

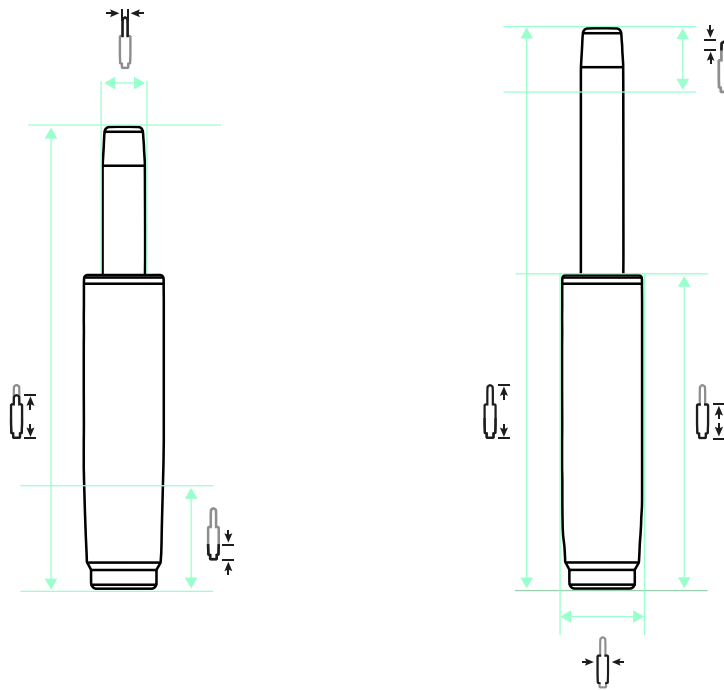

132 mm |
 422 mm |
 290 mm |
 235 mm |
 70 mm |
 33 mm |
 50 mm |
 28 mm |
 320 N

ZUBEHÖR ACCESSORIES



AD 38 / 50



AD 40 / 50



ÜS-Rohr 183



ÜS-Rohr 244



ÜS-Rohr 298

EMPFEHLUNGEN RECOMMENDATIONS



STELLAR 690 Middle 5 P



STELLAR 690 Middle 5 S



North 1 Alu-Mechanik P



Threesixty