

S 285 373 192 K 85 S X

ID 201927

Technisches Datenblatt
Technical data sheet



Spezifikationen Specifications

ID ID	201927	Farbe Colour	schwarz	Gesamthöhe Höchste Total height Highest p	564 mm	Drehbar Rotatable	1
Matchcode Matchcode	S285373192K85SX	Gesamthöhe niedrigs Total height lowest po	373 mm	Standrohrlänge Standpipe length	285 mm		
Bezeichnung 1 Designation 1	S 285 373 192 K 85	Hub Stroke	192 mm	Standrohrdurchmess Standpipe diameter	50 mm		
Artikelgruppe Article group	Standard Line Schw	Gewichtsgrenze Weight limit	140 kg	Aufbauhöhe ab Fuß M Build-up height from	288 mm		
Basismengeneinheit Base quantityunit	Stk	Klasse Class	4	Aufbauhöhe ab Fuß M Installation height fro	479 mm		
Menge Karton Quantity carton	10	Durchmesser Gaseinl Diameter gas unit	28 mm	Material	Stahlblech		
Menge Palette Quantity pallet	420	Konuslänge Gaseinhe Cone length gas unit	33 mm	Druck Pressure	320 N		
Gewicht Weight	1.517 kg	Konuslänge Cone length	85 mm	Höhenverstellbar Heightadjustable	1		

S 285 373 192 K 85 S X

ID 201927

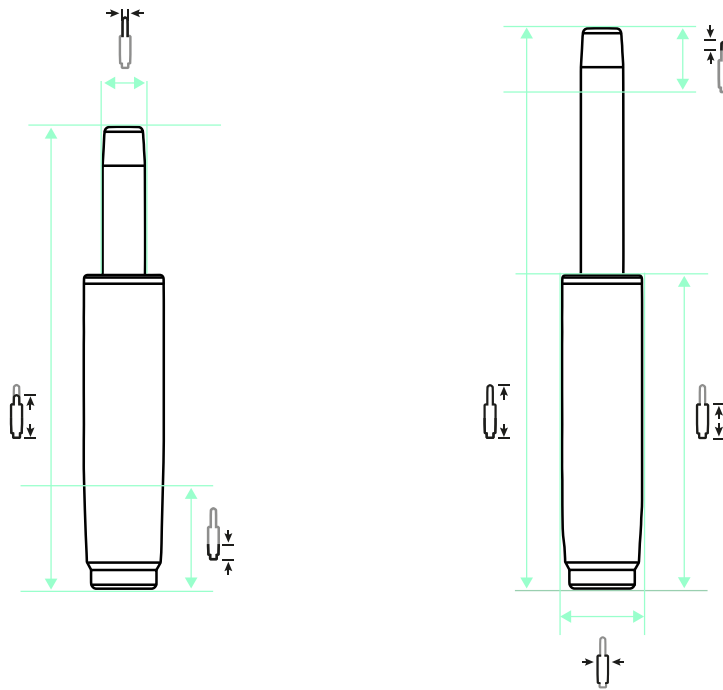

192 mm |
 564 mm |
 373 mm |
 285 mm |
 85 mm |
 33 mm |
 50 mm |
 28 mm |
 320 N

ZUBEHÖR ACCESSORIES



AD 38 / 50



AD 40 / 50



ÜS-Rohr 183



ÜS-Rohr 244



ÜS-Rohr 298

EMPFEHLUNGEN RECOMMENDATIONS



STELLAR 690 Middle 5 P



STELLAR 690 Middle 5 S



North 1 Alu-Mechanik P



Threesixty