

S 40 230 290 132 K 61 C X

ID 201990

Technisches Datenblatt
Technical data sheet



Spezifikationen Specifications

ID ID	201990	Gesamthöhe niedrigs Total height lowest p	290 mm	Standrohrlänge Standpipe length	230 mm	Drehbar Rotatable	1
Matchcode Matchcode	S40230290132K61C	Hub Stroke	132 mm	Standrohrdurchmess Standpipe diameter	40 mm		
Bezeichnung 1 Designation 1	S 40 230 290 132 K	Gewichtsgrenze Weight limit	140 kg	Aufbauhöhe ab Fuß M Build-up height from	229 mm		
Artikelgruppe Article group	Thin Line 40mm	Klasse Class	4	Aufbauhöhe ab Fuß M Installation height fro	361 mm		
Basismengeneinheit Base quantityunit	Stk	Durchmesser Gaseinl Diameter gas unit	28 mm	Material Material	Stahlblech		
Menge Palette Quantity pallet	240	Konuslänge Gaseinhe Cone length gas unit	33 mm	Druck Pressure	320 N		
Gewicht Weight	1.17 kg	Konuslänge Cone length	61 mm	Anschraubbild Bolting pattern	-		
Farbe Colour	chrom	Gesamthöhe Höchste Total height Highest p	422 mm	Höhenverstellbar Heightadjustable	1		

S 40 230 290 132 K 61 C X

ID 201990

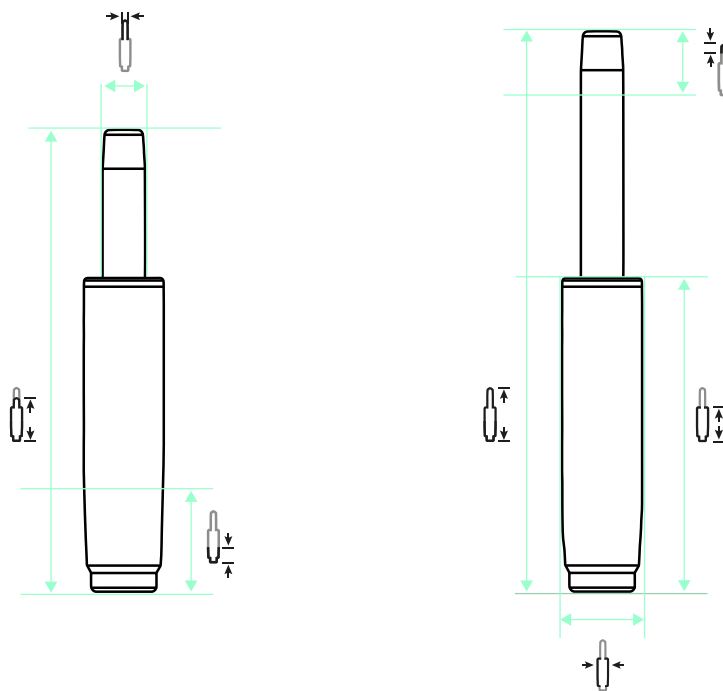

 132 mm |
  422 mm |
  290 mm |
  230 mm |
  61 mm |
  33 mm |
  40 mm |
  28 mm |
  320 N

EMPFEHLUNGEN RECOMMENDATIONS



AF 294 K40 P



North 1 Alu-Mechanik P



Threesixty